

CE

MENU

INVERTERS **GENERATORS**



IS 3.5

IS 4.0

IS 5.0

IS 6.0

GB - INSTALLATION MANUAL

THE GUARANTEE OF THE PRODUCT BECOMES
VOID IF THE SPECIFICATIONS CONTAINED IN THE
FOLLOWING INSTALLATION MANUAL ARE NOT
RESPECTED

1 INSTALLATION

1.1 Characteristics of the installation space	5
1.2 Fastening the unit to the ground	5
1.3 Ventilation	5

2 COOLING WATER CIRCUIT

2.1. Sea water feed system	5
2.2 Typical installation with electric generator above the water-line	9
2.3. Typical installation with electric generator below the water-line	9
2.4. Components	11
2.5. Drainage system	13

3 FUEL CIRCUIT

3.0 Fuel circuit	13
------------------------	----

4 ELECTRICAL CONNECTION

4.1. Battery connection	15
4.2. Control panel connection	15
4.3. A.C. Connection	17
4.4. Generator - Mains Switching	19

1.0. INSTALLATION

1.1. Characteristics of the installation space

The generator must be installed in a sufficiently aired space, supplying a little amount of air necessary for the combustion of the motor.

The space must be separate and acoustically insulated from living areas.

The generator should be positioned so that normal maintenance operations can easily be carried out.

Propulsion motors are recommended for installation in the area as long as they comply with the above-mentioned conditions.

1.2. Fastening the unit to the ground

To fasten the unit securely, a base should be installed to absorb vibrations and support the weight.

Drill holes in the base according to the instructions in fig. 1.

1.3. Ventilation

The generator is equipped with an internal forced cooling system through a water/air exchanger.

The air needed for combustion is taken in through the opening on the base (fig. 2) so care must be taken to ensure that this opening is always free.

2.0. COOLING WATER CIRCUIT

In electric generator, the motor is cooled by an open-circuit system in which sea water circulates.

The capacity of the sea water circuit is 1200 lt / h .

On installation a sea water feed circuit should be fitted for cooling and a waste system to expel the mixture of flue gas and water.

2.1. Sea water feed system

Boats usually use one of two systems to collect water (fig. 3):

- 1 - Direct infeed system
- 2 - System with baffle

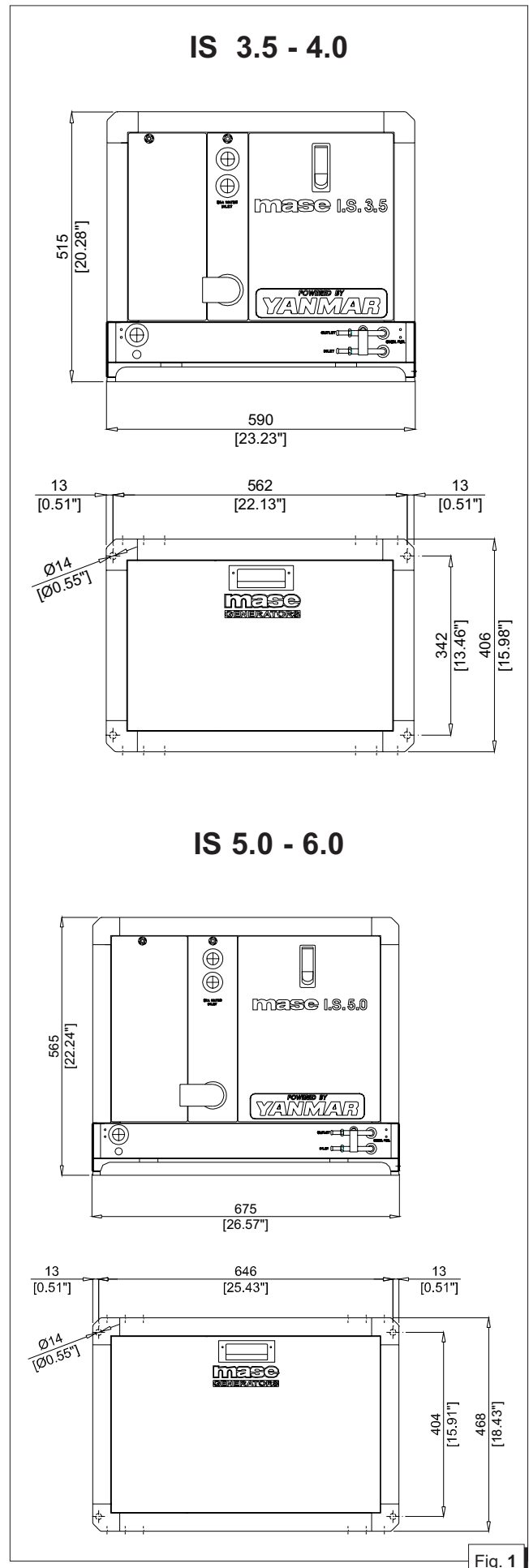

Fig. 1

MASE recommend the direct infeed system ref. 1 fig. 3 since this system prevents water under pressure entering the suction ducts and instead forms a pressure which can easily be overcome by the water pump of the electric generator.

IMPORTANT

Do not apply any type of protective hood to the direct infeed system.

THE DIRECT INFEEED SYSTEM SUPPLIED BY MASE HAS BEEN MODIFIED TO PREVENT SOLID BODIES ENTERING THE SYSTEM AND BLOCKING IT. IF OTHER MATERIALS AVAILABLE ON THE MARKET ARE USED, MORE CARE AND MORE FREQUENT CLEANING IS NECESSARY.

The baffle system might cause the following problems:

- a** - If it is installed with the slots facing the prow.
In this case, during navigation and with the electric generator off, pressure is accumulated in the water infeed duct which might cause the system to fill up, even as far as the exhaust port, allowing water to enter the cylinders.
- b** - If it is installed with the slots facing the stern.
In this case a depression might accumulate in the water infeed duct during navigation, preventing the water pump from starting up the cooling plant, or limiting the capacity and subsequently causing the electric generator to overheat.

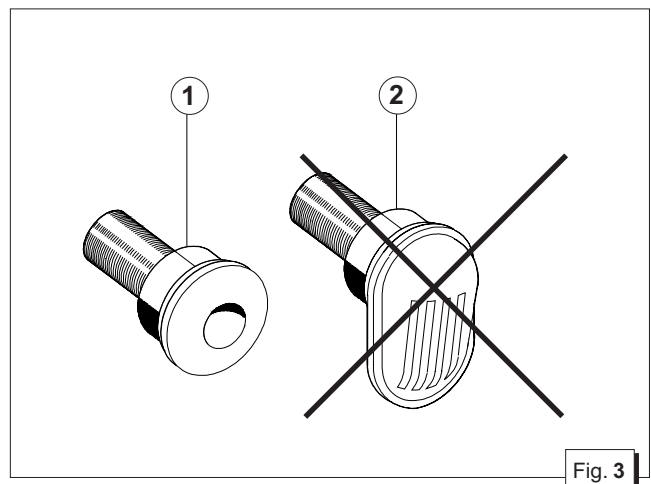
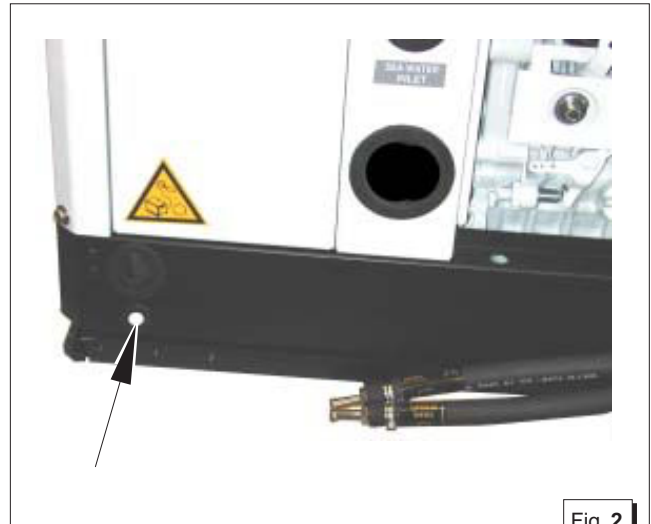

2.2. Typical installation with electric generator above the water-line (fig. 4)

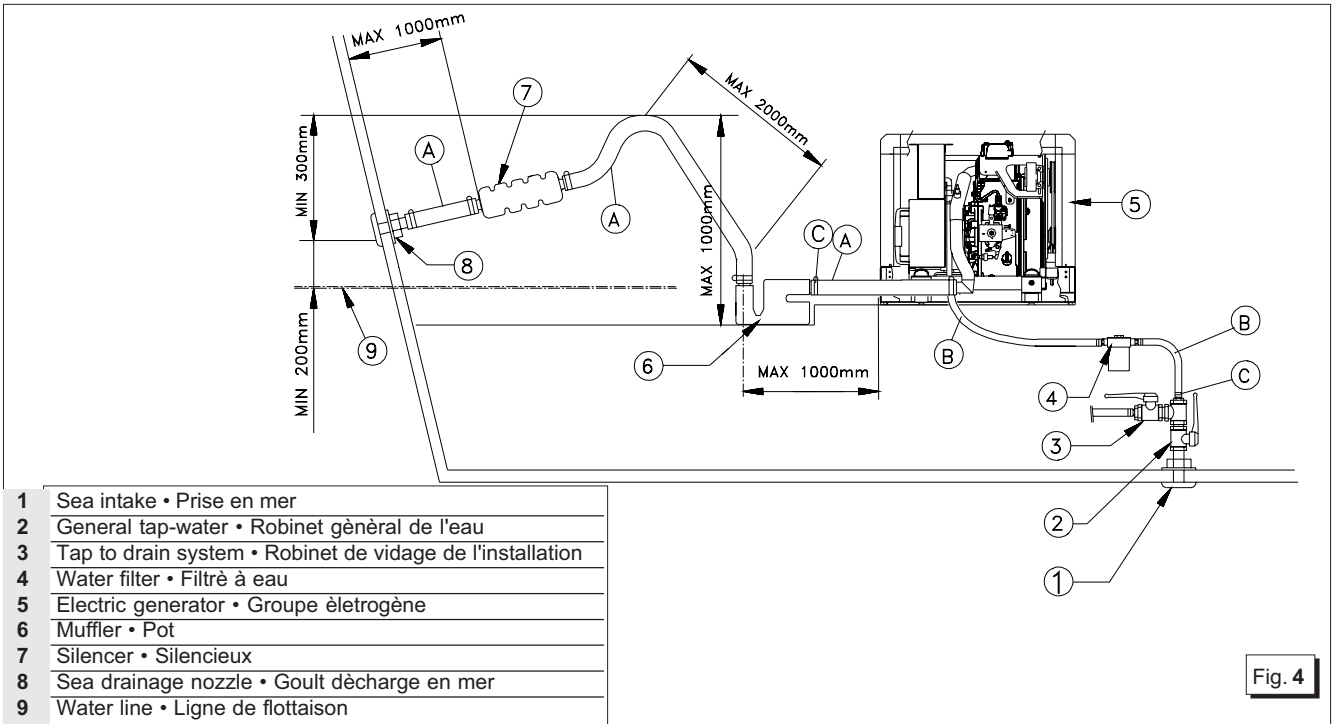

IMPORTANT

- A - Tubes, internal diameter 45 mm
- B - Tubes, internal diameter 15 mm
- C - Clamps

CAUTION

The measurements shown in fig. 4-5 should correspond exactly.

2.3. Typical installation with electric generator below the water line (fig. 5)

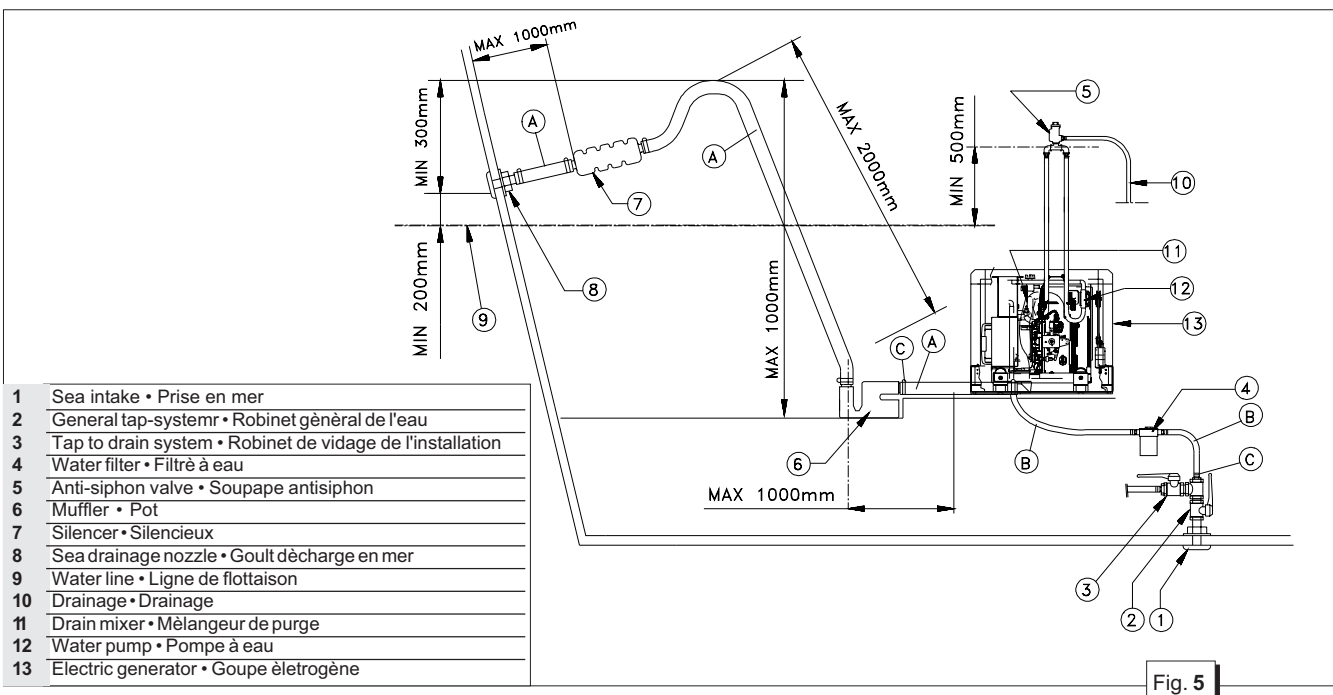

2.4. Components

- 1 - Direct sea intake 1/2"

IMPORTANT

If the unit is installed more than 1 metre above the water-line, a check valve should be fitted after the sea intake (fig. 6, ref. 1) to prevent the water circuit emptying when the motor is off. If this empties, the rotor of the water pump might be damaged during start up; for the same reason, when the unit is first started up, the suction tube from the valve to the pump should be filled manually.

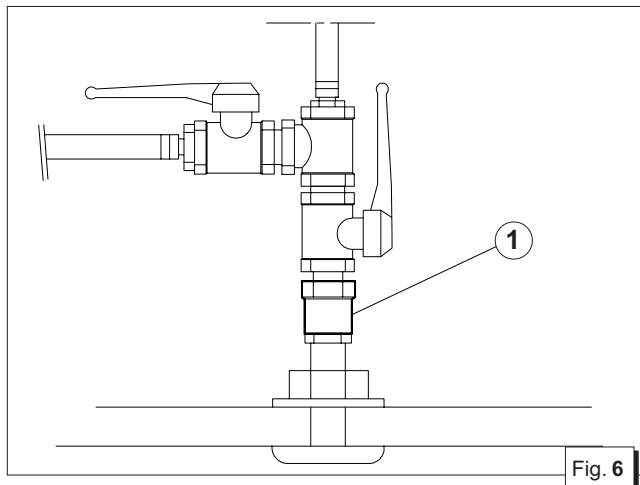

Fig. 6

- 2 - Ball tap (general) 1/2"
- 3 - Ball tap (drainage) 1/2"

This is used to drain the cooling system of the electric generator for general maintenance or when a long period of inactivity is expected.

- 4 - Water filter (can be inspected)
This must provide efficient protection for the cooling circuit from the entrance of mud, sand and seaweed.

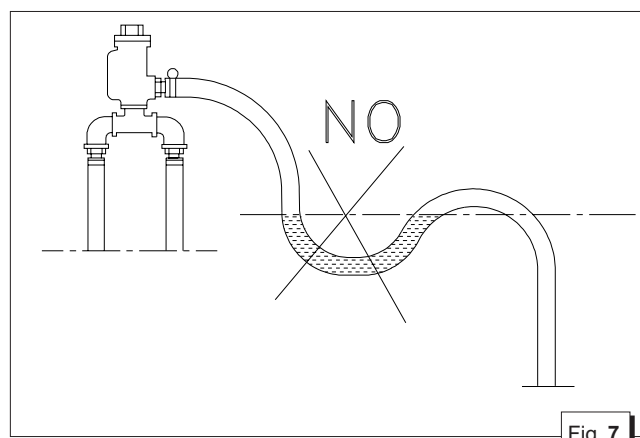

Fig. 7

IMPORTANT

The filter mesh should be very fine. Mesh 2 - 470 micron is recommended, other sizes do not give good filter performance.

- 5 - Anti-siphon valve: this valve returns the cooling circuit to atmospheric pressure when the motor is switched off, to prevent the siphon phenomenon.
It must be installed when the generator is fitted with the drainage mixer on or beneath the water line, and should be positioned at least 50 cm above water level.(see fig. 8/9)

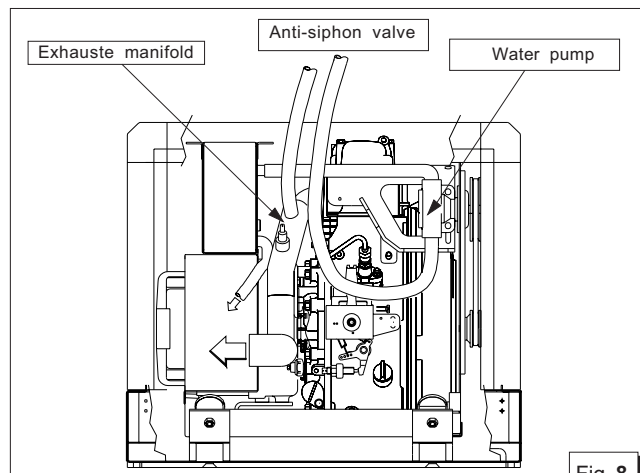

Fig. 8

IMPORTANT

The drainage duct of the anti-siphon valve must run beneath the valve itself in order to prevent water accumulating in the duct, which should always remain empty to allow air to pass through when the unit is switched off. (see fig. 7)

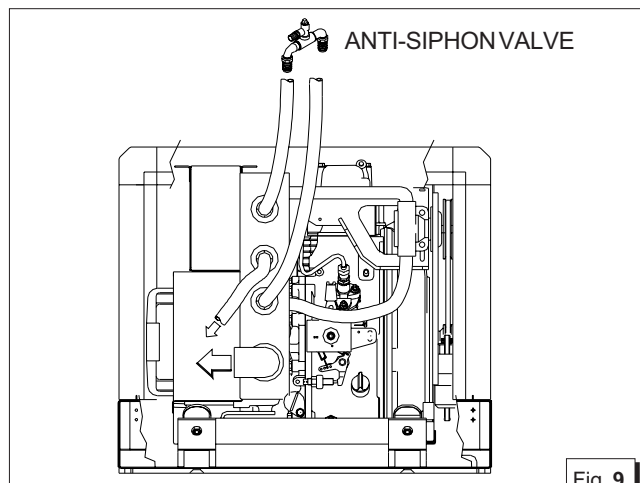
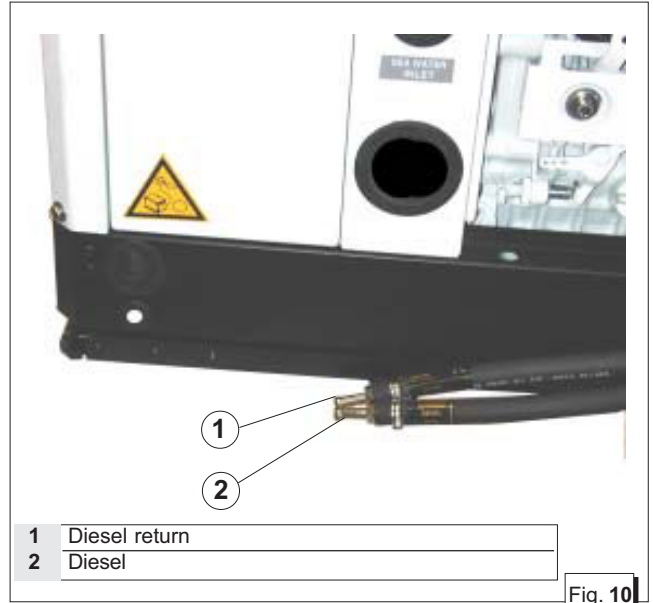

Fig. 9

N.B.: The drainage duct should be taken into the bilge because during normal operation small quantities of water might be leaked from the duct. The box already includes 2 holes to connect the anti-siphon valve (fig. 9).



4.0. ELECTRICAL CONNECTIONS

4.1. Battery connection

To start off the unit an independent battery of 12V is needed, capacity 18 - 30 Ah min.

It should be connected to the clamp of the generator as shown in fig. 11 with cables of section 25 mm² up to distances of 5 metres and with cables of section 35 mm² for longer distances, and following the sequence of operations described below:

- First connect the positive pole (+) of the battery to the terminal marked with the symbol (+) on the generator, (the starter).
- Then connect the negative pole (-) of the battery to the terminal marked with the symbol (-) on the generator.
- Wipe the connections with special mineral grease to protect against oxidation and corrosion.

The generator includes an electronic device to automatically recharge the start-up battery, giving 10 A, at a voltage of 12 V, when fully charged.

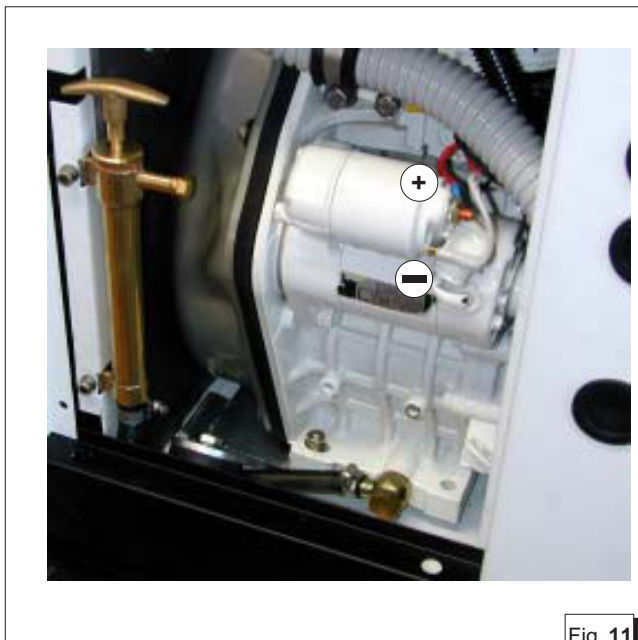

Fig. 11

IMPORTANT

Install the battery in a well-ventilated area, away from the generator and from any device which might produce heat or sparks.

Periodically check the state of the connections of the terminals and the water level of the battery. If the cables need to be disconnected, follow the instructions for connection in reverse order.

Do not invert the poles of the connecting cables since serious damage might be caused to the generator and the battery.

Do not connect other loads to the battery.

In order to reduce galvanic currents to a minimum, the (-) of the battery of the electric generator should not be connected to the (-) of the other batteries on board.

4.2. Control panel connection

This connection can be made through the terminal boards (fig. 12, ref. 1) using the cables provided already connected to the control panel. The terminals to be used are those marked no. 1 to no. 9 for the control cables. The earths braid should be connected to the faston terminal (fig. 12, ref. 2) insulating them carefully and using a pre-insulated female faston. In making the connections it is important to follow the diagram and the colours codes as indicate (fig. 13). Fasten the cable with the provided plastic support on the bail (fig. 12, ref. 3).

The control panel contains 5 LEDs for operation and alarm (fig. 14, ref. 1), an hour counter (fig. 14, ref. 2) and the start and stop buttons (fig. 14, ref. 3/4/5).

For fixing the control panel is necessary to perforate as shown in fig.14.

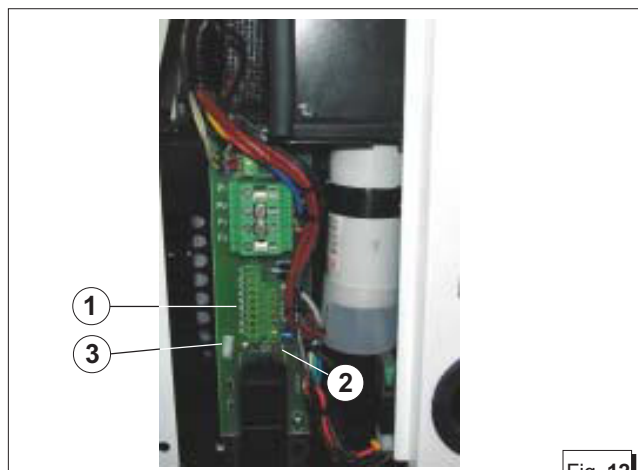

Fig. 12

ALLACCIAMENTO C.PANEL C.PANEL CONNECTION BRANCHEMENT C.PANEL				
NUMERAZIONE SCHEDA COMANDI PRINTED CIRCUIT NUMBERING NUMERATION CARTE COMMANDES		COLORE	COLOUR	COULER
9x0.35mm ²	1	MARRONE	BROWN	MARRON
	2	BIANCO	WHITE	BLANC
	3	BLU	BLUE	BLEU
	4	GRIGIO	GREY	GRIS
	5	VERDE	GREEN	VERT
	6	ROSA	PINK	ROSE
	7	GIALLO	YELLOW	JAUNE
	8	NERO	BLACK	NOIR
	9	ROSSO	RED	ROUGE
	$\frac{\perp}{=}$	CALZA METALLICA	EARTH BRAID	CONDUCTEUR METALLIQUE

Fig. 13

4.0. ELECTRICAL CONNECTIONS

4.1. Battery connection

To start off the unit an independent battery of 12V is needed, capacity 18 - 30 Ah min.

It should be connected to the clamp of the generator as shown in fig. 11 with cables of section 25 mm² up to distances of 5 metres and with cables of section 35 mm² for longer distances, and following the sequence of operations described below:

- First connect the positive pole (+) of the battery to the terminal marked with the symbol (+) on the generator, (the starter).
- Then connect the negative pole (-) of the battery to the terminal marked with the symbol (-) on the generator.
- Wipe the connections with special mineral grease to protect against oxidation and corrosion.

The generator includes an electronic device to automatically recharge the start-up battery, giving 10 A, at a voltage of 12 V, when fully charged.

IMPORTANT

Install the battery in a well-ventilated area, away from the generator and from any device which might produce heat or sparks.

Periodically check the state of the connections of the terminals and the water level of the battery. If the cables need to be disconnected, follow the instructions for connection in reverse order.

Do not invert the poles of the connecting cables since serious damage might be caused to the generator and the battery.

Do not connect other loads to the battery.

In order to reduce galvanic currents to a minimum, the (-) of the battery of the electric generator should not be connected to the (-) of the other batteries on board.

4.2. Control panel connection

This connection can be made through the terminal boards (fig. 12, ref. 1) using the cables provided already connected to the control panel. The terminals to be used are those marked no. 1 to no. 9 for the control cables. The earths braid should be connected to the faston terminal (fig. 12, ref. 2) insulating them carefully and using a pre-insulated female faston. In making the connections it is important to follow the diagram and the colours codes as indicate (fig. 13). Fasten the cable with the provided plastic support on the bail (fig. 12, ref. 3).

The control panel contains 5 LEDs for operation and alarm (fig. 14, ref. 1), an hour counter (fig. 14, ref. 2) and the start and stop buttons (fig. 14, ref. 3/4/5).

For fixing the control panel is necessary to perforate as shown in fig.14.

IMPORTANT

The control panel is indispensable for operating the unit and must be installed; do not use devices other than the control panel supplied with the unit since they might not be compatible with the generator. Make the connections with the battery disconnected.

CAUTION

The control panel is provided with a connecting cable 10 metres long. This cable should not be modified since it might cause the panel circuit to function incorrectly.

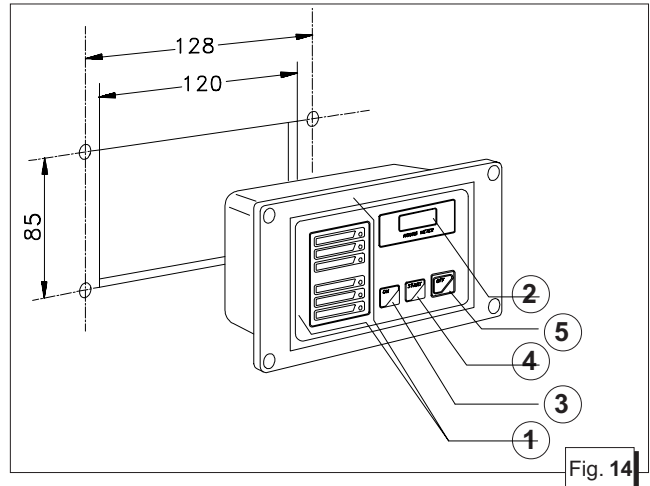

Fig. 14

4.3. A.C. Connection

This connection can be done through the power terminal board (fig. 15, ref. 1) placed inside the derivation box.

This range includes the possibility of use both at 110V 50Hz - 120V 60Hz and 220V 50Hz - 240V 60Hz.

For this reason it is possible to make two types of connection (and use), according to the following configurations.

1 - Parallel configuration: in this configuration there is a single output at 110 (120)V between points P_1 and F_2 , connecting the outputs of the alternator (P_1, F_1, P_2, F_2) as shown in the diagram in fig. 16.

2 - Serial connection; in this configuration it is possible to use a voltage of 220 (240) V between points P_1 and F_2 , as shown in the diagram in fig. 17.

In serial connection, power can be picked up both at 110 (120) V between points $F_1 - F_2$ and $P_1 - P_2$ and at 220 (240) V between points P_1 and F_2 at the same time, as shown in the diagram in fig. 18.

It is also possible to feed two separate lines as shown in fig. 19 on the outputs $P_1 - F_1$ and $P_2 - F_2$.

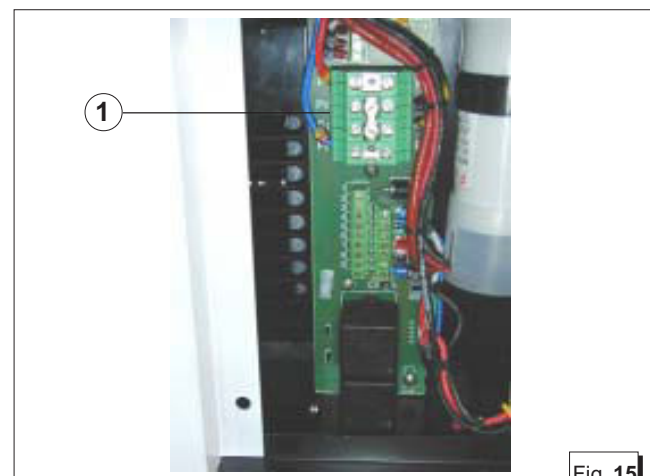

Fig. 15

N.B. In this case the power which can be taken from each of the two outputs is half the rated nominal power.

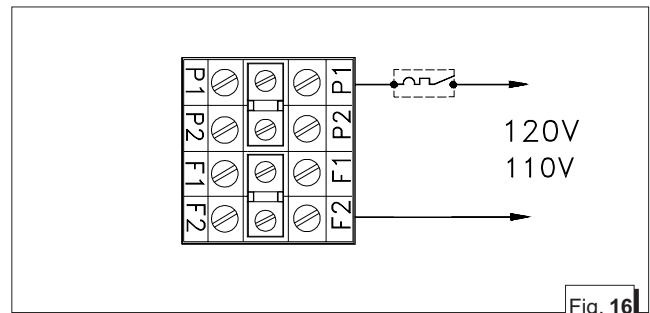

Fig. 16

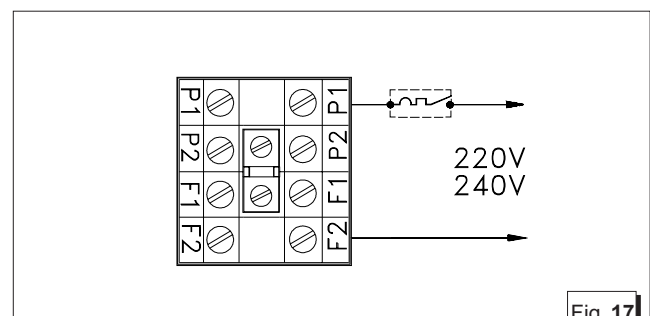

Fig. 17

- Ensure that the sum of the loads to be supplied does not exceed the nominal power of the electric generator.
- Magnetothermic protective devices or similar should be placed between the generator and electrical equipment, according to the tables shown below.
- To make both parallel and serial connections, use the special bridges provided in the accessories to the electric generator on the terminal board fig. 15 ref. 1.

Single voltage distribution

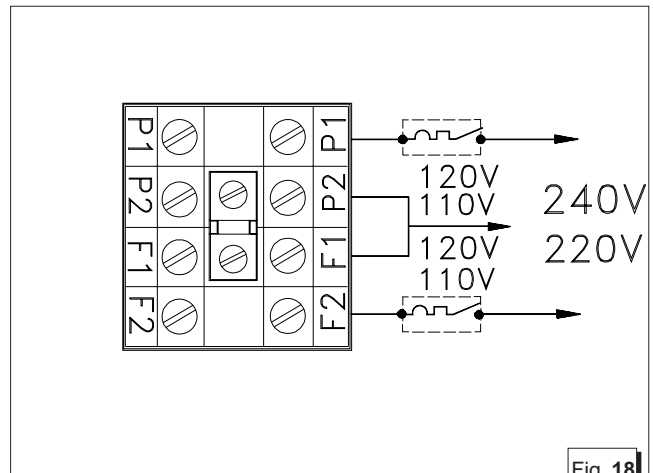

Fig. 18

IS 3.5

Hz	50	60	50	60
V	110	120	220	240
W.	2700	2900	2700	2900
A	24.5	24.2	12.3	12.1

TAB 1

IS 5.0 - 6.0

Hz	50	60	50	60
V	110	120	220	240
W.	4000	4800	4000	4800
A	36.5	40	18	20

N.B: In these cases just one magnetothermic device should be installed, see fig. 16/17.

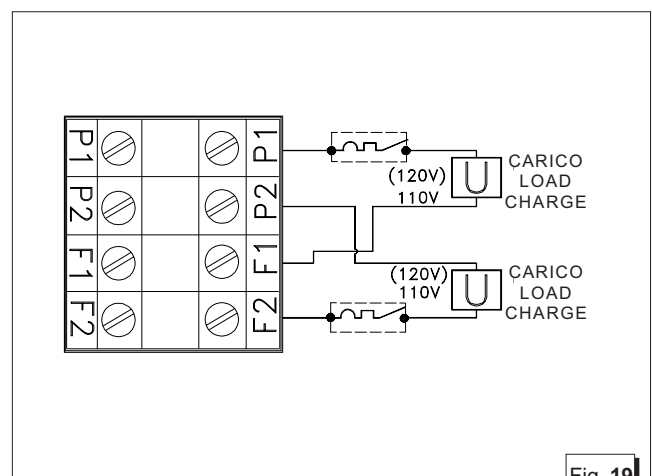

Fig. 19

Double voltage distribution

	IS 3.5	IS 5.0 - 6.0
Hz	50	50
V	110/220	110/220
W	2700	4000
A	12.3	18
Hz	60	60
V	120/240	120/240
W	2900	4800
A	12.1	20

N.B: In these cases two magnetothermic devices should be installed, see fig. 18/19, dimensioned on the current values (A) shown in Table. 2.

4.4. Generator - Mains switching

A switch should be placed on the line to switch the user appliances from the generator to an external power line. The switch should be dimensioned according to the size of the loads: a general diagram is shown in fig. 20.

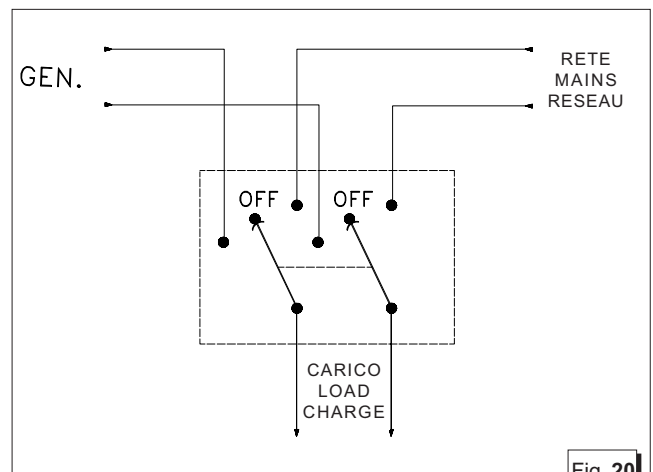

Fig. 20



Fig. 21