

IS 11.5 T **B**

Rev.0 A.A. 24/02/2015

cod.43378

Tipo modello
N° matricola
Codice

**This manual has to be preserved for all through life of the
gen set to which ago reference**

GB



Thank you for having chosen a product MASE.

As a leading generator manufacturer, Mase Generators offers a wide range of generators with an output from 1 KVA portable generators to 1600 KVA units for special applications.

Founded in 1970, the Cesena-based company extends over a area of 16,000 square meters, including a 9,000 sq. mtr. manufacturing facility.

Mase Generators began as a company producing 500 Watt, light and compact portable generators. These generators

made the Mase Generators name well known throughout the world. Mase Generators is a leader in high quality, reliable products, and innovative research performed by Research and Development Department.

The generator you have purchased is the fruit of years of experience in the sector and for the modern conception, the strong sizing, the materials employees, the continuous updatings, constitutes an effective answer to the operators' demands of the sector.

This Manual instructions will furnish you useful information and precious suggestions so you can fully exploit all the possibilities that the generators offers you.

If any part of the manual resulted incomprehensible, please contact us.

In to renew our thanks we cordially greet you.



MASE GENERATORS S.p.A. Via Tortona, 345
47023 Cesena (FC) Italy
Tel.+39-0547-354311 Fax.+39-0547-317555

Technical data, informations, layouts of the texts and graphic preparations: edited by the Technical Office
Mase Generators

THE COMPANY MASE GENERATORS SPA RESERVES ALL RIGHTS TO IMPLEMENT MODIFICATIONS TO THIS PRESENT MANUAL WITHOUT ADVANCE NOTICE OR NOTIFICATION, WHEN NECESSARY, IN ACCORDANCE WITH ITS POLICY OF CONTINUAL PRODUCT IMPROVEMENT. THE MASE GENERATORS SPA, RESERVES ALL THE RIGHTS ON THE MANUAL PRESENT. ANY TOTAL OR PARTIAL REPRODUCTION IS PERMITTED WITHOUT WRITTEN AUTHORIZATION OF THE MASE GENERATORS SPA.

CONTENTS

DEFINITIONS USED	5		
PRELIMINARY PRESCRIPTIONS	7		
1 GENERAL INFORMATIONS	6	6 MAINTENANCE	34
1.1 Conform use	8	6.1 Preamble	34
1.2 Residual risks	8	6.2 Routine engine maintenance	34
1.3 Safety symbols	9	6.3 Engine oil check	34
1.4 Symbols on the generator group	10	6.4 Engine oil change	35
1.5 Safety label informations	11	6.5 Oil filter	35
1.6 Reference documents	15	6.6 Replacing / cleaning the fuel pump filter	36
1.7 Reference regulations and legislative provisions ..	15	6.7 Replacing the line fuel filter	36
1.8 Marking	15	6.8 Draining the water/fuel separator	36
1.9 Identification of the generator unit	15	6.9 Cleaning the water/fuel separator	36
2 GENERAL CHARACTERISTICS	16	6.10 Bleeding the fuel system	37
2.1 Composition of generator unit	16	6.11 Air filter	37
2.2 Command and control panel	17	6.12 Draining the cooling system	37
2.3 Table of technical characteristics	18	6.13 Replacing the zinc anode	37
3 INSTALLATION	19	6.14 Seawater pump maintenance	38
3.1 General housing characteristics	19	6.15 Checking / replacing the v-belt	38
3.2 Lifting	19	6.16 Checking / replacing the alternator v-belt	39
3.3 Anchoring the generator	19	6.17 Alternator maintenance	39
3.4 Ventilation	19	6.18 Battery maintenance	39
3.5 Cooling water circuit	20	6.19 List of recommended spare parts	40
3.5.1 Seawater feed system	20	6.20 Periods of inactivity	40
3.5.2 Components	21	6.21 Period checks and maintenance	41
3.5.3 Typical installation	22	6.22 Anomalies, causes and remedies	42
3.5.4 Exhaust system	25	6.23 How to order the spare parts	42
3.6 Fuel circuit	26	7 TRASPORT, STORAGE, LIFTING, HANDLING AND PACKAGING	43
3.6.1 Fuel filter	26	7.1 Transport and storage	43
3.6.2 Electric pump	26	7.2 Lifting and handling of the packed generator unit	43
3.7 Electrical connections	27	8 GUARANTEE AND RESPONSABILITY	44
3.7.1 Battery connection	27	8.1 Guarantee	44
3.7.2 Control panel connection	27	8.2 Limits of responsibility	44
3.7.3 A.C. connection	28	9 DISPOSAL	44
3.7.4 Generator-network switching	29	9.1 Disposal of the waste materials deriving from maintenance and scrapping	44
3.7.5 Emergency stop	29	10 WIRING DIAGRAMS	45
4 USING THE GENERATOR	30	10.1 Wiring diagrams	45
4.1 Preliminary checks	30		
4.2 Fuelling	30		
4.3 Starting the generator	31		
4.4 Stopping the generator	31		
4.5 Emergency stop	31		
5 SAFETY SWITCHES AND WARNING SIGNALS	32		
5.1 Engine protection module	32		
5.2 Protection against short circuits and overload ..	33		
5.3 Protection against short-circuit of low voltage electrical system	33		
5.4 Fuses	33		

DEFINITIONS USED

The terms used are current technical terms, and where considered necessary the meaning is described below

- **Generator**
An assembly of an internal combustion piston engine and an alternate current, synchronous, 2-4 pole, self-excited generator, joined together to create a station for self-production of electrical energy.
- **User system**
Composed of the power supply circuits of the user equipment, including the relevant sectioning, handling, breaking, transformation, protection, etc. devices which do not form part of the production, transmission and distribution systems.
- **Category 1 electrical system**
A system where the rated voltage is greater than 50 V and smaller than 1000 V including alternate current.
- **Load**
A set of numerical values of electrical and mechanical magnitudes which characterise the requirements imposed on a rotary machine by an electrical circuit or by a mechanical device at a certain instant.
- **Thermal switch**
Main cut-out and breaking device made up of a switch which opens automatically by thermal effect.
- **Differential switch**
Main cut-out and breaking device made up of a switch which opens automatically by differential effect.
- **Skilled person**
A person with technical know-how or sufficient experience to allow him to avoid the dangers inherent in electricity.
- **MASE specialised personnel**
A person able to evaluate the job assigned to him and recognise the possible dangers on the basis of training at the MASE training centres, with professional experience and knowledge of the equipment in question and of the possible dangers deriving in the event of negligent behaviour.
- **Supplier**
A body (e.g. manufacturer, agent, installer) which supplies the equipment or services relating to the machine.
- **Control**
Control action by which an output variable of the controlled system (controlled variable) is affected by an input variable of the controlling system in order to achieve a certain goal.
- **Manual control**
Control where the change of a variable handled is produced by a person through manual intervention.
- **Automatic control**
Control where the change of a variable handled is produced by a controlling device (automatic controller) without the intervention of a person.
- **Danger**
Source of possible harm or damage to health.
- **Protection**
Guard or protection device as safety measure to protect persons from a present or potential danger.
- **Casing**
Part intended to assure protection of the equipment against specific outside influences and protection in every sense against contacts.

GB**Connection in bad state**

The live parts are not fully covered with insulation removable by destruction only, the connections are not secure because of unstable tightening of the parts and a development of oxide between the parts.

- Direct contact

Contact of persons or animals with live parts.

- Control circuit

Circuit used to control machine operation.

- Equipment

General term which comprises materials, devices, equipment, accessories and similar used in conjunction with an electrical installation.

PRELIMINARY PRESCRIPTIONS

GB

FIELD OF EMPLOYMENT:

THE GENERATOR IS PROPER FOR TO PRODUCE IN WAY AUTONOMOUS ELECTRIC ENERGY IN THE LIMITS OF TENSION AND WATT DECLARED BY THE BUILDER



Consult this manual carefully before proceeding to the use and to any operation on the genset.

FAILURE TO RESPECT THE SPECIFICATIONS CONTAINED IN THIS USE AND MAINTENANCE MANUAL WILL RESULT IN FORFEITURE OF THE GUARANTEE ON THE PRODUCT.

This manual was drawn up by the manufacturer and forms an integral part of the generator equipment, definition used as indicated in Directive 98/37/EC; the information contained in the manual is addressed to all the persons involved in the operating life cycle of the generator, and is necessary to inform both those who effectively carry out the different operations and those who coordinate the activities, to arrange the necessary logistics and to regulate access to the place where the generator will be installed and operated.

This manual was drawn up by the manufacturer with the purpose of providing essential information and instructions for proper use and maintenance in conditions of safety. It constitutes an integral part of the generator equipment and must carefully be protected from any agent which may damage it for the entire life cycle of the generator. The manual must accompany the generator if transferred to another user or owner.

It is opportune to remember the supplied generator group needs installation. The technician will release, at the end of the work, a declaration to the meaning of the normative applied.

The manual defines the purpose for which the generator was constructed and contains all the information necessary to guarantee safe and proper use. Constant observance of the instructions contained in this manual guarantees the safety of the operator, protection against damage to persons or things, operating economy and a longer life of the generator.

The drawings are provided by way of example. Even if the generator in your possession differs from the illustrations contained in this manual in elements of little significance, for example the colour, the safety of the generator and the information provided are nevertheless guaranteed.

To facilitate consultation, it has been divided into sections identifying the main concepts; for a quick look at the topics, consult the index.

Ongoing improvement and development of the product may have led to modifications to the generator which are not included in this publication.

Whenever a problem concerning the generator or this publication arises, consult with Mase Generators SPA for the latest information available.

1 GENERAL INFORMATIONS**1.1 CONFORM USE**

The generator is suitable for independent production of electrical energy within the voltage and wattage limits declared by the manufacturer.

Any other use outside the already stated field of use is prohibited: the generator is intended for marine use.

The generator has been designed to operate independently (without operator) if not for sporadic checks.

The limits of use are:

- operating temperature: -10°C (14°F), +40°C (104°F)
- relative humidity: 30% - 90%
- the generator is suitable for marine operation.

Installations are subject to approval by **mase** or by an installer authorised by **mase**.

Arbitrary modifications to the machine are prohibited for safety reasons.

Original spare parts must be used on pain of losing machine conformity.

All the operations that require dismantling of special parts may only be carried out by technicians authorised by the local dealer or the manufacturer.

Only **mase** technicians or personnel trained by **mase** have the necessary knowledge of the generator and the special equipment as well as the experience to carry out any operation in the most economical and reliable way.

1.2 RESIDUAL RISKS

The generator has been designed taking into account the safety regulations set out in the EC directives and standards; nonetheless, the following residual risks remain:

- injury caused by contact with hot parts during maintenance.
- injury caused by electrocution during maintenance on the electric panel.
- risks connected with long periods of exposure to the noise of the generator (with open cowling).
- risks due to contact with the generator lubricants during maintenance.
- risks due to the fire hazard the fuel represents.

Because of the typical intrinsic danger of the Generators, you are reminded that, although the generator has been designed, constructed and tested in accordance with the safety regulations, only proper and careful use can guarantee full safety; to this end, the various precautions to be taken during use of the Generator are listed below.

SAFETY INSTRUCTIONS

The electromechanics equipments, included the generating sets, switch, command electric equipments and accessories, can cause damages to people and, if they are installed, used or maintained with not qualified operations, they can put in serious danger the life of people. To avoid accidents is necessary to know the potential risks and operate with caution. Read and follow all the precautions and the instructions for the safety. PRESERVE THESE INSTRUCTIONS.

The manual shows varied typologies of precautions and instructions for the safety: Danger, Warning, Caution.

1.3 SAFETY SIMBOLS



Indicates that particular attention must be paid in order to prevent serious risks which could lead to death or possible harm to the health of personnel.



A condition which may occur during the lifetime of a product, system or plant considered at risk regarding damage to persons, property, the environment or economic loss.



Indicates that particular attention must be paid in order to prevent serious consequences which could result in damage to tangible goods, such as the resources or the product.

Other symbols on this manual



Particular important instructions



Indicates components and non inclusive parts with the base configuration.



Carefully consult this manual before using or carrying out any operation on the generator.



The routine maintenance operations, must be carried out by qualified personnel who have the appropriate equipment and protections.

1.4 SYMBOLS ON THE GENERATOR GROUP

GB

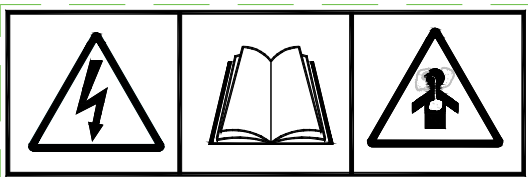

Cod. 42653

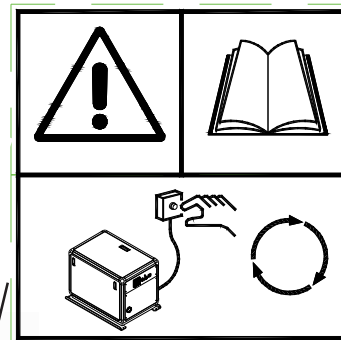

Cod. 42655

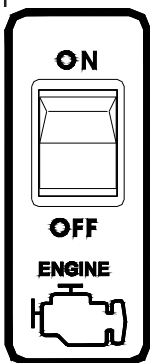

Cod. 42657

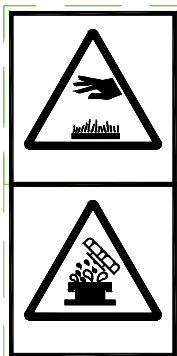

Cod. 41781

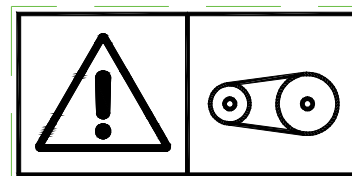



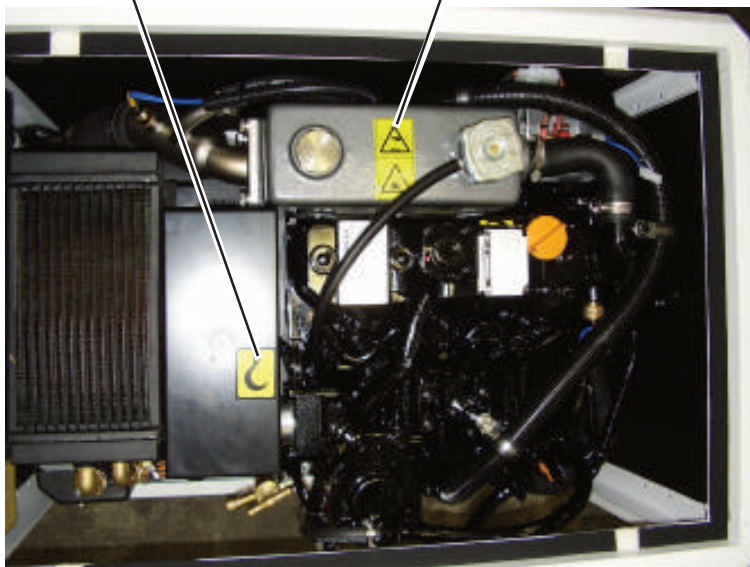



Cod. 42656

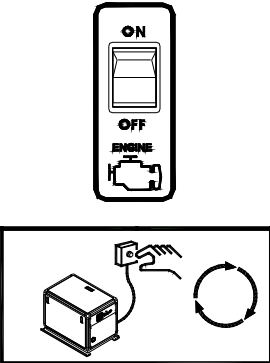

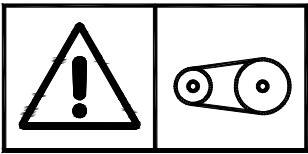





1.5 SAFETY LABEL INFORMATIONS

- These labels warn the user of any danger which may cause serious injury. Carefully read the meaning and the precautions described in this manual.
- If the label detaches or becomes illegible, replace it with a new one which can be requested from an authorised **mase** dealer.

Danger Symbols	Description
	<p>HOT PARTS</p> <p>Hot engine and exhaust system. Can cause severe injury or death. Do not work on generator set until it is allowed to cool.</p> <p>Servicing exhaust system. Hot parts can cause severe injury or death. Do not touch hot engine parts. An engine becomes hot while running and exhaust system components become extremely hot.</p> <p>Hot coolant and steam. Before removing the pressure cap, stop the generator set and allow it to cool. Then loosen the pressure cap to relieve pressure.</p>
	<p>ACCIDENTAL STARTING</p> <p>Accidental starting. Can cause severe injury or death. The generator is started from a remote control panel. In order to prevent accidental starting, set the emergency switch to the (OFF) position. Disconnect the negative pole from the starter battery.</p> <p>Disabling generator set. Accidental starting can cause severe injury or death. Before working on the generator set or connected equipment, disable the generator set as follows: 1) Disconnect power to battery charger, if equipped. 2) Remove battery cables (remove negative (-) lead first). 3) Reconnect negative (-) lead last when reconnecting battery. Follow these precautions to prevent starting of generator set by the remote start/stop switch or by the onboard switch.</p>
	<p>Hazardous voltage. Moving rotor. Can cause severe injury or death. Operate generator set only with all guards and electrical enclosures in place.</p>
	<p>MOVING PARTS</p> <p>Rotating parts. Can cause severe injury or death. Do not operate generator set without all guards, screens, and covers in place.</p>
	<p>PREVENTING FIRE</p> <ul style="list-style-type: none"> • Be sure to use the proper diesel fuel. • Be sure to stop the engine before refueling. • If you spill fuel, wipe off such spillage completely. • Never place oil or other flammable materials (such as straws, withered grass) close to the engine during running or shortly after shutting it down. • Check fuel oil and engine oil for leakage from their piping lines to cause fires.

Danger Symbols	Description
	<p>PREVENTING FIRE</p> <hr/> <p>Can cause severe injury or death.</p> <ul style="list-style-type: none"> • Start • Start the engine only from a starter switch without any load or in neutral position of the clutch of machine unit. <p>The machine unit suddenly starts to move or generates power to cause serious personal injury.</p> <ul style="list-style-type: none"> • Keep the machine unit sufficiently away from a building and flammable materials during engine running. It may cause fires due to hot exhaust gas and engine body. • Keep sparks, open flames or any other form of ignition (match, cigarette, etc.) away when fueling / refueling. Fire and or an explosion may result. <p>FIRE</p> <hr/> <p>Can cause severe injury or death.</p> <p>In case of fire, do not open the chest</p> <p>Extinguish the generator fire and immediately unload the whole content of the portable extinguisher through the hole indicated by the label.</p>
	<p>EXHAUST SYSTEM</p> <hr/> <p>Carbon monoxide.</p> <p>Can cause severe injury or death.</p> <p>The exhaust system must be leakproof and routinely inspected.</p> <p>Carbon monoxide symptoms.</p> <p>Carbon monoxide can cause severe nausea, fainting, or death.</p> <p>Carbon monoxide is a poisonous gas which is present in exhaust gases.</p> <p>Inspecting exhaust system.</p> <p>Carbon monoxide can cause severe nausea, fainting, or death.</p> <p>In addition to routine exhaust system inspection, install a carbon monoxide detector.</p> <p>Consult your boat builder or dealer for approved detector installation. Inspect your detector before each generator set use. Test the carbon monoxide detector function per the manufacturer's instructions and keep it operational at all times.</p> <p>Installing exhaust system.</p> <p>Carbon monoxide can cause severe nausea, fainting, or death.</p> <p>In addition to routine exhaust system inspection, install a carbon monoxide detector.</p> <p>Use the following precautions when installing and operating generator set.</p> <p>Do not install exhaust outlet where exhaust can be drawn in through portholes, vents, or air conditioners.</p> <p>If the generator set exhaust discharge outlet is near the waterline, water could enter the exhaust discharge outlet and close or restrict the flow of exhaust.</p>

Danger Symbols	Description
	<p>EXHAUST SYSTEM</p> <p>Carbon monoxide. Group generator use. Carbon monoxide can cause severe nausea, fainting, or death.</p> <p>Carbon monoxide is an odorless, colorless, tasteless, non irritating gas, able to, if inhaled only also for brief time to provoke the death. Be especially careful if operating the generator set when moored or anchored under calm conditions as gases may accumulate. If operating the generator set dockside, moor the ccraft so that the exhaust discharges on the lee side (the side sheltered from the wind). Alway be aware of others-make sure your exhaust is directed away from other boats and buildings.</p>
	<p>HAZARDOUS VOLTAGE / ELECTRICAL SHOCK</p> <p>Hazardous voltage. Moving motor. Can cause severe injury or death. Operate generator set only with all guards and electrical enclosures in place.</p> <p>Grounding generator set. Hazardous voltage can cause severe injury or death. Electroconduction is possible whenever electricity is present. Open main circuit breakers of all power source before servicing equipment. Configure the installation to electrically ground the generator set and electrical circuits when in use. Never contact electrical leads or appliances when standing in water or on wet ground, as the chance of electroconduction increases under such conditions.</p> <p>Disabling generator set. Hazardous voltage can cause severe injury or death. To disable the generating set from load, turn off the the automatic switch of the line or disconnect the output cables from the commutation switch and block the final part of cables. Hazardous voltage to load during an ispection cold cause severe damages to people and to equipment. Do not use the emergency button instead the automatic switch of the line.</p>
	<p>Battery short circuit. Explosion can cause severe injury or death. Short circuits can cause severe damages to people and/or equipment. Disconnect the battery before doing installation operations o generator set maintenances. Remove all jewels before doing maintenance on the maintenance. Remove negative (-) lead first when disconnecting battery. Reconnect negative (-) lead last when reconnecting battery. Never connect negative battery lead (-) to positive lead (+) of starting solenoid.</p>

Danger Symbols	Description
 	<p>BATTERY</p> <hr/> <p>Do not touch the electrolytic battery acid</p> <p>Sufficient ventilation of the battery area.</p> <ul style="list-style-type: none"> • Keep the area around the battery well ventilated, paying attention to keep sparks, open flame and any other form of ignition away. During engine running or charging battery, hydrogen gas is produced from the battery and can be easily ignited. <p>Battery acid. Sulfuric acid in batteries can cause severe injury or death.</p> <p>Sulfuric acid in battery can cause permanent damage to eyes, burn, skin, and hole in clothing.</p> <p>Always wear splash-proof safety goggles when working near the battery. If battery acid is splashed in the eyes or skin, wash immediately the affected area with large quantity of clean water. Seek immediate medical aid in case of eyes contact.</p> <p>Do not intentionally make the battery spark by short-circuiting to check its remaining charge. It will cause fires.</p> <p>If the battery electrolyte frozen, recharge the battery after warming up to thaw it.</p>
	<p>SAFETY CLOTHING</p> <hr/> <p>Do not expose your skin to high pressure fuel spray</p> <p>Be careful so as not to bring your skin in contact with high pressure fuel spray from broken fuel injection pipe to penetrate your skin to cause inflamed. If exposing to the spray should occur, obtain prompt medical treatment.</p> <p>Beware of dirt from air blowing</p> <p>Wear protective equipment such as goggles to protect your eyes when blowing compressed air or steam. Dust or flying debris can hurt eyes.</p>

1.6 REFERENCE DOCUMENTS

The instructions for use provided with each generator are made up of a collection of documents of which this manual represents the General Part. The following documents are normally provided separate.

- a **CE** declaration of conformity.
- b Instruction manual for use and maintenance of the generators,(this manual).
- c Engine use and maintenance manual.
- d List of **mase** Service Centres.
- e **mase** Warranty certificate.
- f Warranty card.
- g EPA certificate (Engine manufacturing)

1.7 REFERENCE REGULATIONS AND LEGISLATIVE PROVISIONS

The generator groups, built by **mase**, destined to the countries of the European Community, are conforming to the applicable **EC** directives, and they are provided of a **EC** Declaration of Conformity.

EN 12601: Reciprocating internal combustion engine driven generating sets.

98/37/EC and subsequent amendments:
Essential machine requirements for safety and health protection ("Machine" directive).

73/23/EC and subsequent amendments contained in the directive **93/68/EC** : Guarantee of safety of electrical material intended for use within certain voltage limits, ("Low Voltage" Directives).

EN 60204.1: Electrical equipment of machines.



1.8 MARKING

The generator identification plate carries all the identification data conforming to **ISO 8528** and in accordance with the provisions for **EC** marking for those cases where required. Below is a facsimile of the identification plate fixed on the hull of each generator.

1.9 IDENTIFICATION OF THE GENERATOR UNIT

- 1 - Machine name
- 2 - Machine code
- 3 - Serial number
- 4 - Rated power
- 5 - Declared frequency
- 6 - Rated power factor
- 7 - Rated voltage
- 8 - Rated current
- 9 - Degree of protection
- 10 - Class of isolation
- 11 - Temperature max. of use
- 12 - Altitude max. of use
- 13 - Performance class
- 14 - Year of construction
- 15 - Manufacturer - Adress
- 16 - Weight

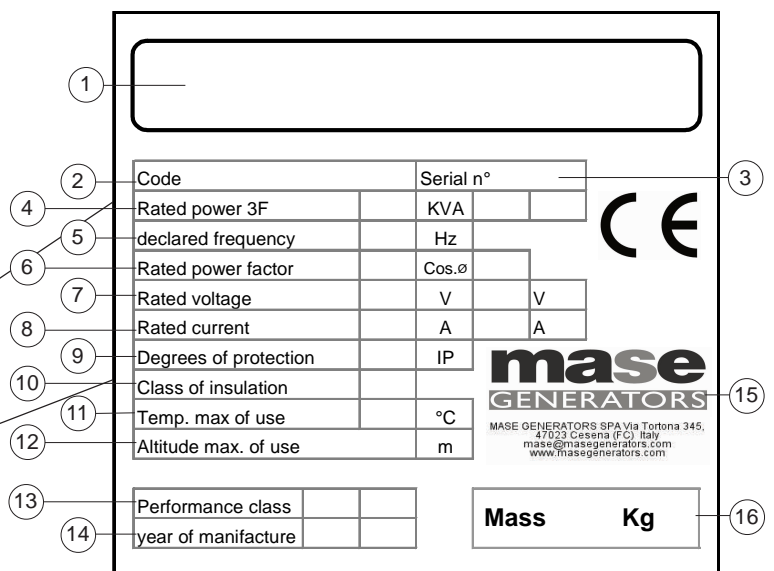

INFORMATION

The machine code number, the serial number and the year of construction must always be indicated when contacting the manufacturer for information, order of spare parts, etc..

2 GENERAL CHARACTERISTICS

The generators have been designed for use in the marine field, using highly reliable 1500/1800 rpm air/water-cooled diesel engines. Particular attention has been paid to the degree of protection against external agents, engine protection and protection of the electrical parts against overload or overheating, adopting automatic systems able to stop the generator in the event of malfunctioning.

The generator is particularly quiet thanks to an internally insulated soundproof casing and an advanced soundproof system for combustion smoke exhaust.

The alternators used are the synchronous self-energized type.

2.1 COMPOSITION OF GENERATOR UNIT

The generator unit is essentially composed by the following components.

- 1 - Fixed frame
- 2 - Upper openable cowling
- 3 - Beside openable cowling
- 4 - Electric connection cowling
- 5 - Anchorage stirrup
- 6 - Emergency button
- 7 - Exhaust gas and cooling water connection
- 8 - Seawater intake connection
- 9 - Tank connections
- 10 - Engine air filter
- 11 - Check / refill oil cap
- 12 - Oil extraction pump
- 13 - Oil filter
- 14 - Fuel pump filter
- 15 - Seawater pump
- 16 - Fuel pump
- 17 - Water/air radiator
- 18 - Engine high temperature sensor
- 19 - Mixer high temperature sensor
- 20 - Starting motor
- 21 - rpm regulation screw
- 22 - Battery connection lead (+)
- 23 - Battery connection lead (-)
- 24 - Remote control panel connector
- 25 - Zinc anode
- 26 - Water/water radiator

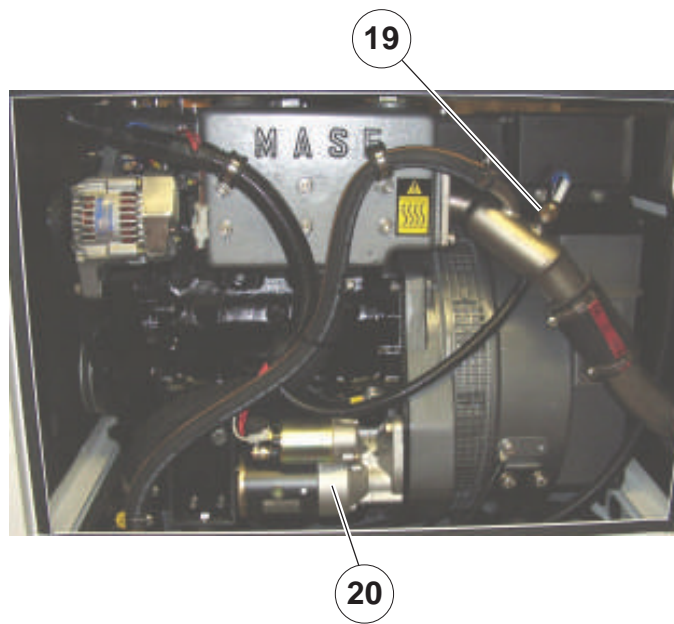
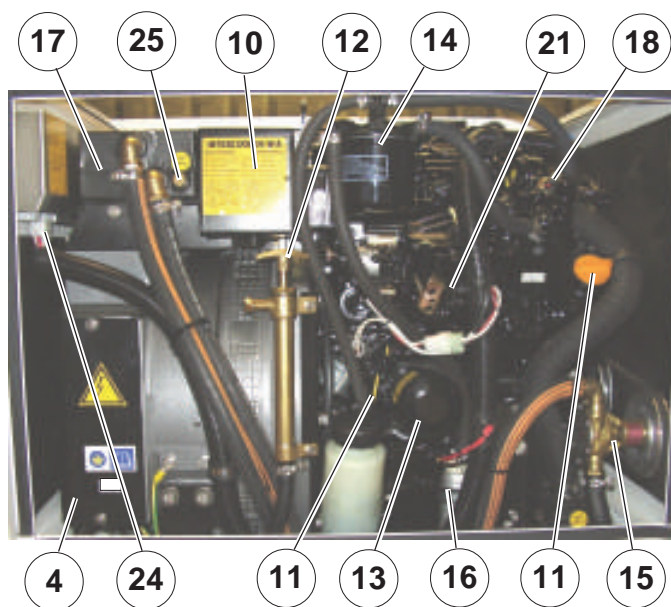
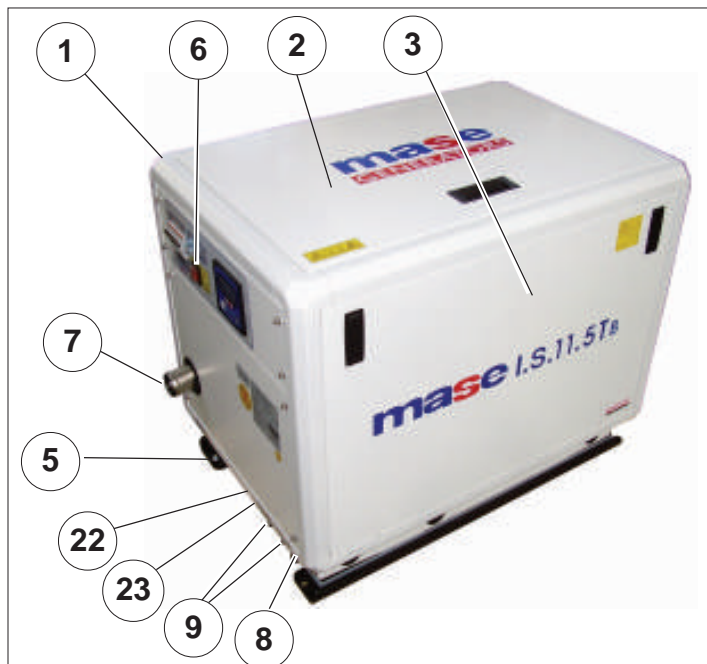



2.2 COMMAND AND CONTROL PANEL (STANDARD VERSION)

Each generator is fitted with an instrument panel for commands and controls with the following components:

- 1) Emergency button
- 2) General magnetothermal switch
- 3) DC magnetothermal switch
- 4) Engine protection module
- 5) Display
- 6) START / STOP switch
- 7) START / Preheating switch
- 8) Scroll UP navigation menu
- 9) Scroll DOWN navigation menu
- 10) OK pushbutton

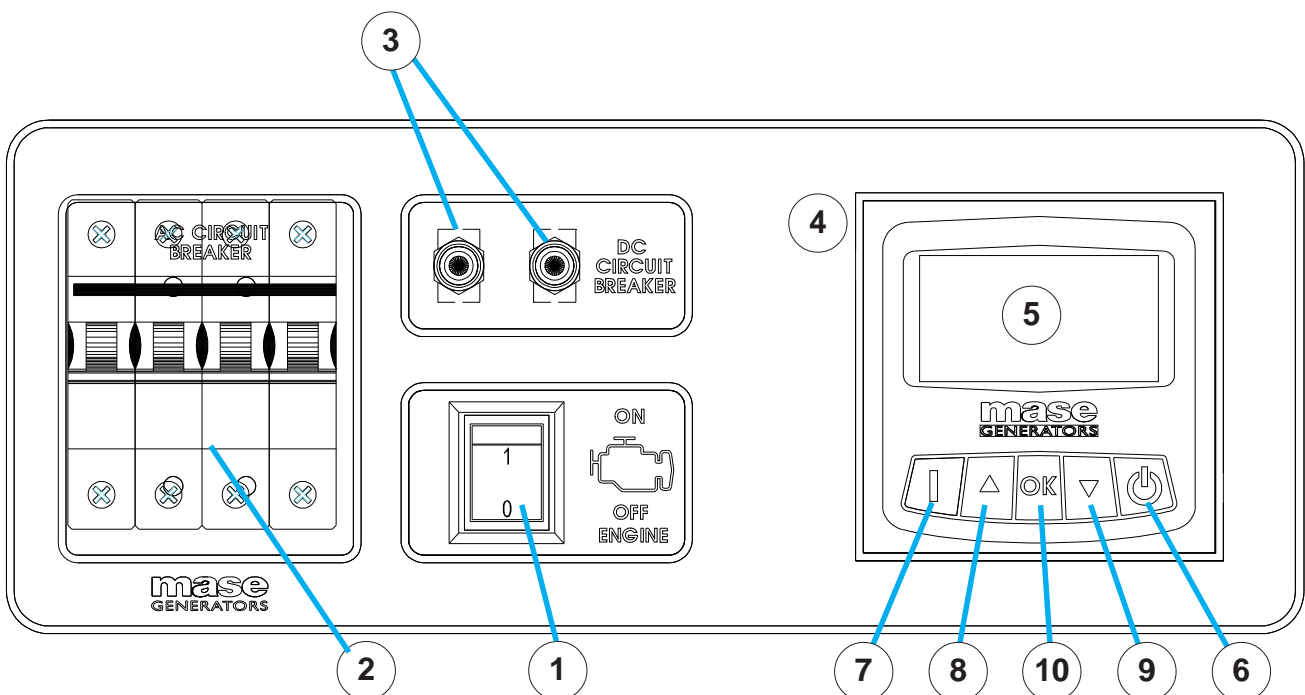

2.3 TECHNICAL CHARACTERISTICS TABLE

GB

MODEL		IS 11.5 T	
GENERAL FEATURES			
MAX POWER (LTP) ¹		11,2	kVA
CONTINUOUS POWER (PRP) ²		10,2	kVA
POWER FACTOR (Cos Φ)		0,8	
RATED VOLTAGE		400	V
RATED FREQUENCY		50	Hz
GRADE OF PROTECTION		IP 23	
MAX TEMP. OF USE		40 - 104	°C - °F
MIN TEMP. OF USE		-5 - 23	°C - °F
MAX ALTITUDE OF USE		1000 - 3280	m - ft
MAX TILT OF USE (PERIODICAL 3 min)		30°	
MAX TILT OF USE (CONTINUOUS)		25°	
PORTATA POMPA ACQUA MARE		25 - 6,6	L/min - gal/min
DIMENSIONS	L	837 - 32,9	mm - in.
	W	568 - 22,4	mm - in.
	H	688 - 27,1	mm - in.
MASS		295 - 655	kg - lbs
ENGINE			
TYPE		4 STROKE	
MANUFACTURER		YANMAR	
MODEL		3 TNV 82 GMG	
DISPLACEMENT		1330 - 81,2	cm ³ - in ³
MAX POWER		15,4 - 11,5	HP - kW
n° OF CYLINDERS		3	
CYLINDERS / HEAD MATERIAL		CHAST IRON	
RATED SPEED		1500	rpm
SPEED CONTROL		CENTRIFUGAL / MECCANICAL	
INDUCTION SYSTEM		NATURAL	
FUEL		DIESEL	
INJECTION SYSTEM		INDIRECT	
FUEL FEEDING PUMPS		ELECTRIC	
MAX PREVALENCE FUEL PUMP		700 - 27,5	mm - in.
FULL LOAD CONSUMPTION		3,2 - 0,84	L/h - gal/h
COOLING		WATER / WATER	
LUBRIFICATION SYSTEM		FORCED	
OIL SUMP CAPACITY		5,5 - 1,45	L - gal
COMBUSTION AIR VOLUME		0,65 - 22,9	m ³ /min - cfm
ELECTRIC PLANT		12 (negative pole to ground)	V
STARTING		ELECTRIC	
STARTING MOTOR		12 - 0,9	V - kW
STARTING BATTERY		12 - 70	V - Ah
BATTERY CHARGER		12 - 40	V - A
STOPPING SYSTEM		STOP SOLENOID VALVE	
ALTERNATOR			
TYPE		SYNCHRONOUS, SELF-REGULATED	
n° OF POLES		4	
MAX CURRENT		16,2	A
ISOLATION CLASS		H	
VOLTAGE REGULATOR		SELF-EXCITED	
VOLTAGE STABILITY		± 2%	
FREQUENCY STABILITY		± 5%	
COOLING		AIR / WATER	

(1) Limited - time running power (LTP) ISO 8528-1

It is the maximum power that, under the environment conditions established by the norm ISO 3046/1, the generator group it is able to disburse for a maximum of 500 hours for year, of which a maximum of 300 hours among the interval of maintenance prescribed by the builder. It is accepted the operation to this power conditions the duration of the group.

An overload of the 10% is admitted only for regulation.

(2) Prime power (PRP) ISO 8528-1

It is the available maximum power for a variable power cycle that the generator group is able to disburse for a boundless number of hours for year among the interval of maintenance prescribed by the builder and under the environment conditions established by the norm ISO 3046/1. The middle power during a period of 24 hours, doesn't have to exceed 80% of the PRP.

An overload of the 10% is admitted only for regulation.

3 INSTALLATION

⚠ DANGER

The generator may only be installed by qualified technicians. Malfunctioning due to improper installation may cause injury or death.

3.1 GENERATOR HOUSING CHARACTERISTICS

- The generator must be installed in a sufficiently ventilated room able to assure the small amount of air required for engine combustion.
- The room must be acoustically separated and isolated from the living quarters.
- The generator must be positioned in such a way as to facilitate normal maintenance operations.
- It is advisable to install the generator in the propulsion engine room provided that it meets the above conditions.
- The air must be clean.
- The air temperature in the place of installation must be between -5°C (23°F) and +40°C (104°F).
- The relative humidity must not exceed 50% at a maximum temperature of +40°C (104°F). Relative humidity of 90% at +20°C (68°F) and 100% at +25°C (77°F) is permissible.

3.2 LIFTING

To lift the generator place the hook in the hole (ref.1) *Always take these precautions when lifting the generator:*

- Do not swing suspended loads.
- Never leave the load unattended.
- Lower the generator to the ground very slowly.
- Always maintain the safety distance.

⚠ CAUTION

All the lifting operations must be carried out by personnel specialised in this type of work, such as truck drivers, crane drivers, slingers. The operator is considered responsible for using the correct machine slinging and lifting technique.

3.3 ANCHORING THE GENERATOR

For fixing the generator set predispose an adapted plinth to sustain the weight and vibrations of the generator. Proceed then to the perforation of the plinth following the indications in (ref.2).

3.4 VENTILATION

The generator is equipped with an internal forced cooling system through a water/air exchanger. The amount of air required for combustion is aspirated through the intake located on the base (ref.3): Therefore, always check that this intake is free of any obstruction.

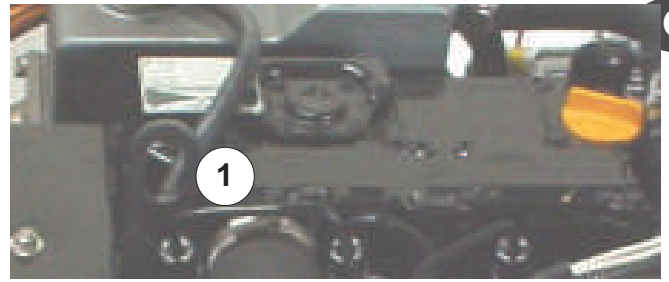

GB

2

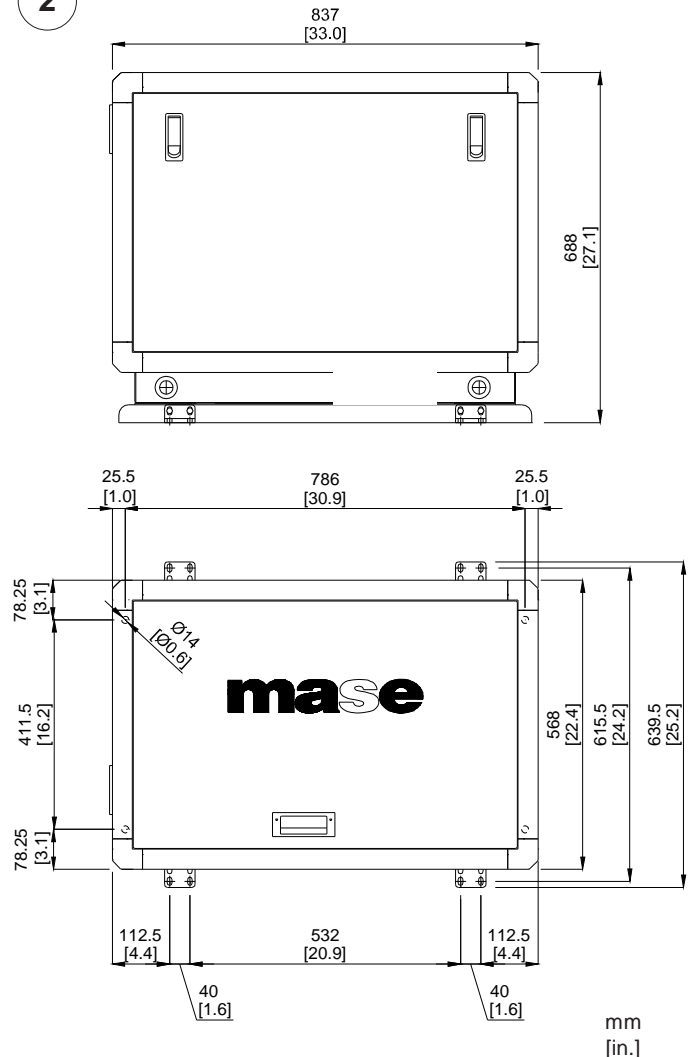

3



GB

3.5 COOLING WATER CIRCUIT

The generator engine is cooled by an open-circuit system in which seawater circulates.

At the time of installation, a seawater feed circuit must be arranged for cooling, and an exhaust system for the combustion gas and water mixture.

3.5.1 SEAWATER FEED SYSTEM

Two water intake systems are normally adopted on boats:

- Direct intake system (**ref.1**).
- System with baffle (**ref.2**).

mase recommends using the direct intake system (**ref.1**), since it prevents intake of pressurised water into the intake ducts, instead generating a vacuum easily overcome by the water pump head of the generator.

⚠ CAUTION

Do not fit any type of protection cap on the direct intake system.

The system with baffle (**ref.2**), on the other hand, may cause the following problems:

a- If mounted with the slots facing the bow:

In this case, during navigation and with the generator off, pressure is created in the water intake duct, which may cause the system to fill up until reaching the exhaust port, thus making it possible for water to enter the cylinders.

b- If mounted with the slots facing the stern:

In this case, during navigation a vacuum may be created in the water intake duct such as to inhibit the water pump to activate the cooling system or such as to limit the flow rate with consequent overheating of the generator.

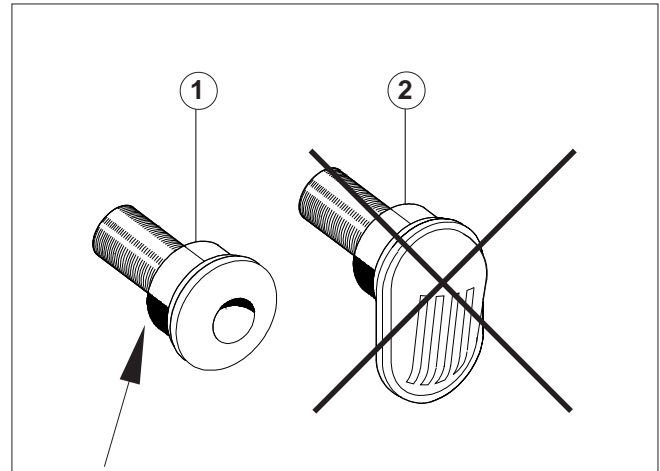

3.5.2 COMPONENTS

CAUTION

If the generator is installed at a height over 1m (3,3ft) above the waterline, a check valve (ref.2) must be fitted after the seawater intake to prevent the water circuit from emptying out when the engine is off. If the circuit is empty, the water pump impeller may be damaged during starting. For the same reason, when starting the generator for the first time, manually prime the intake pipe leading from the valve to the pump.

- 1/2" direct seawater intake (ref.1).
- 1/2" ball cock (main system) (ref.3).
- 1/2" ball cock (system bleeding) (ref.4).
- Serves to drain the cooling system of the generator for general maintenance or for long periods of inactivity.
- Water filter (inspectable) (ref.5).
It protects effectively the cooling circuit against intake of mud, sand and seaweed.

INFORMATION

The filter mesh must be the fine type, it is advisable to use the type with 2-470µm (micron) pitch. Different sizes would not allow good filter efficiency.

- Antisiphon valve (ref.6): this valve brings the cooling circuit to atmospheric pressure when the engine is off, preventing the siphonage phenomenon. **It must be used when the base of the generator is under the water line**, and must be positioned at least 500mm (1.6ft) above sea level.

INFORMATION

The drain pipe of the antisiphon valve must be positioned under the valve thus preventing water from accumulating in the pipe which must always remain empty to allow air to pass through it when the generator is switched off.

It is advisable to run the drain pipe through the bilge, as small amounts of water may flow from it during normal operation. Two holes have been made in the casing to connect the antisiphon valve (ref.6).

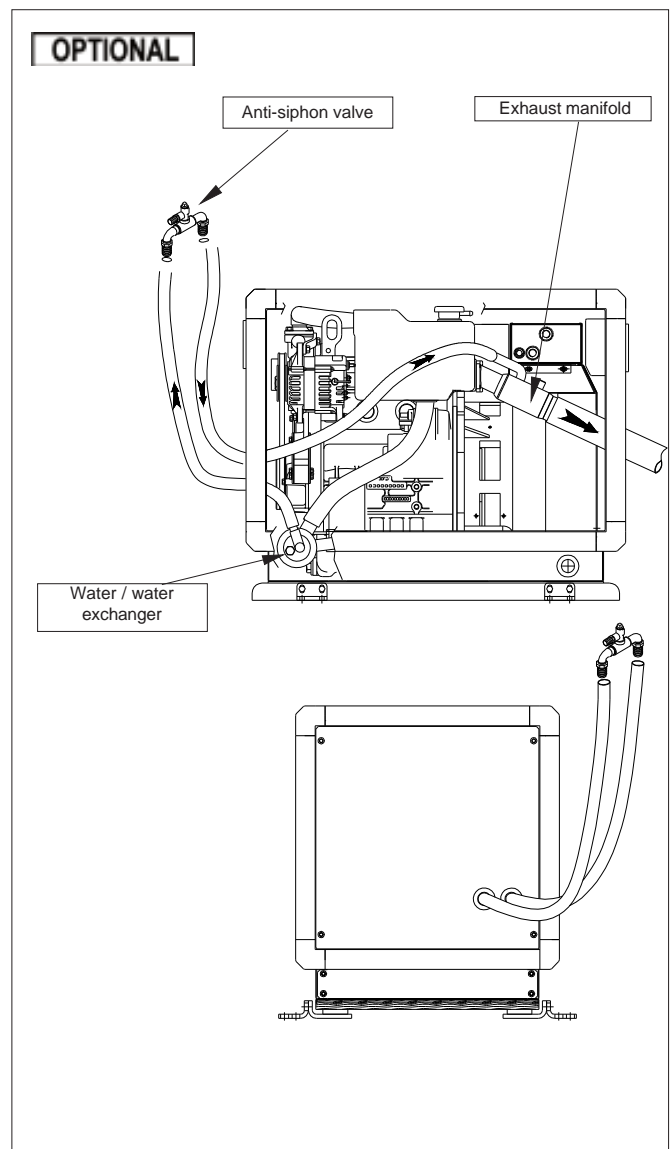
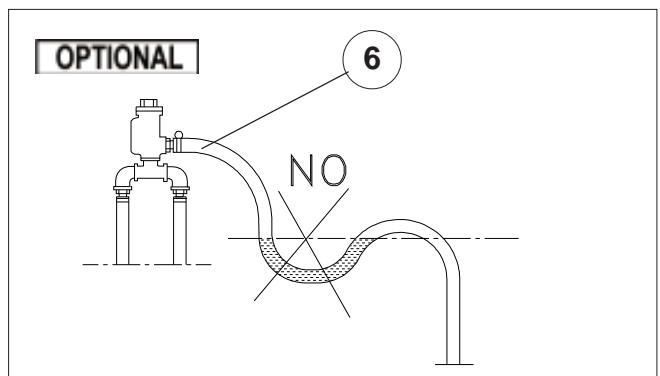
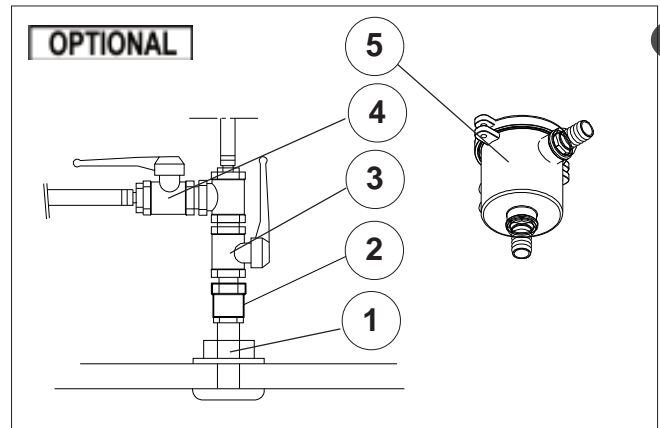

3.5.3 TYPICAL INSTALLATIONS

TYPICAL INSTALLATION WITH GENERATOR ABOVE THE WATERLINE

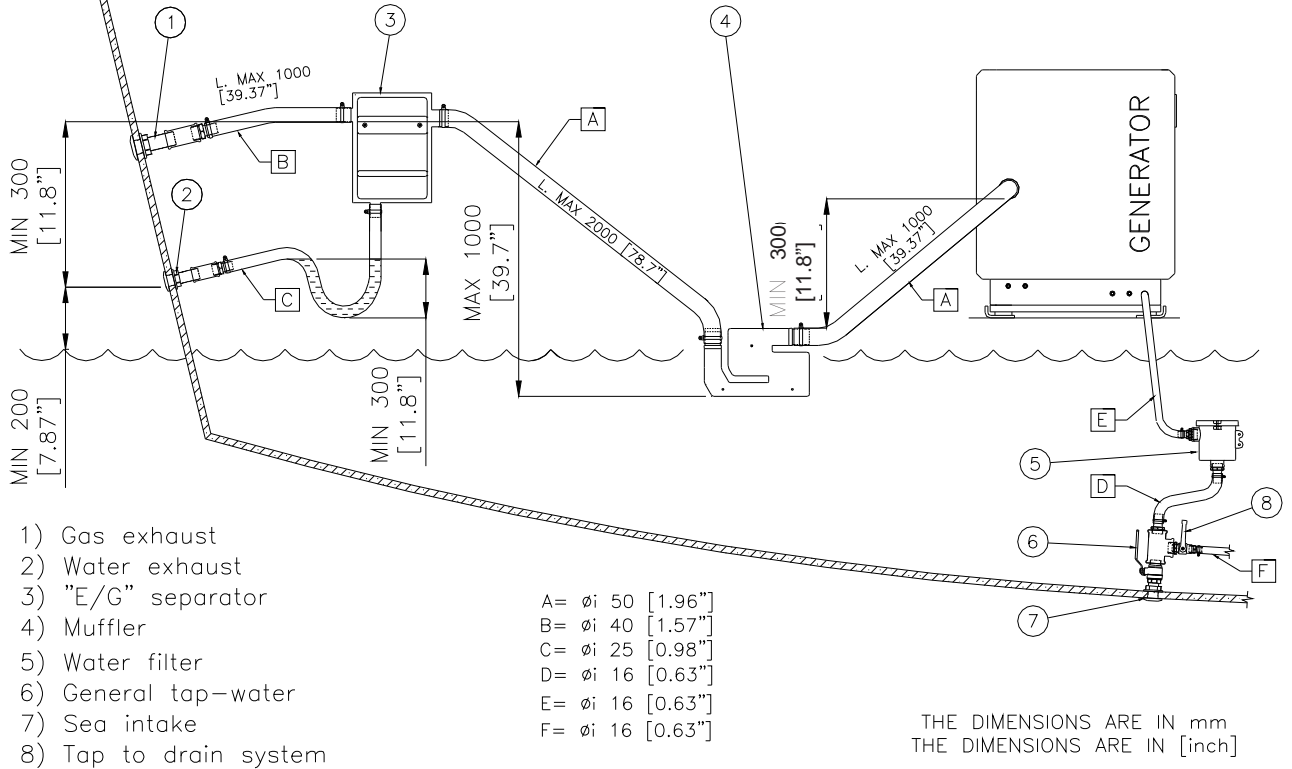

TYPICAL INSTALLATION WITH GENERATOR UNDER THE WATERLINE

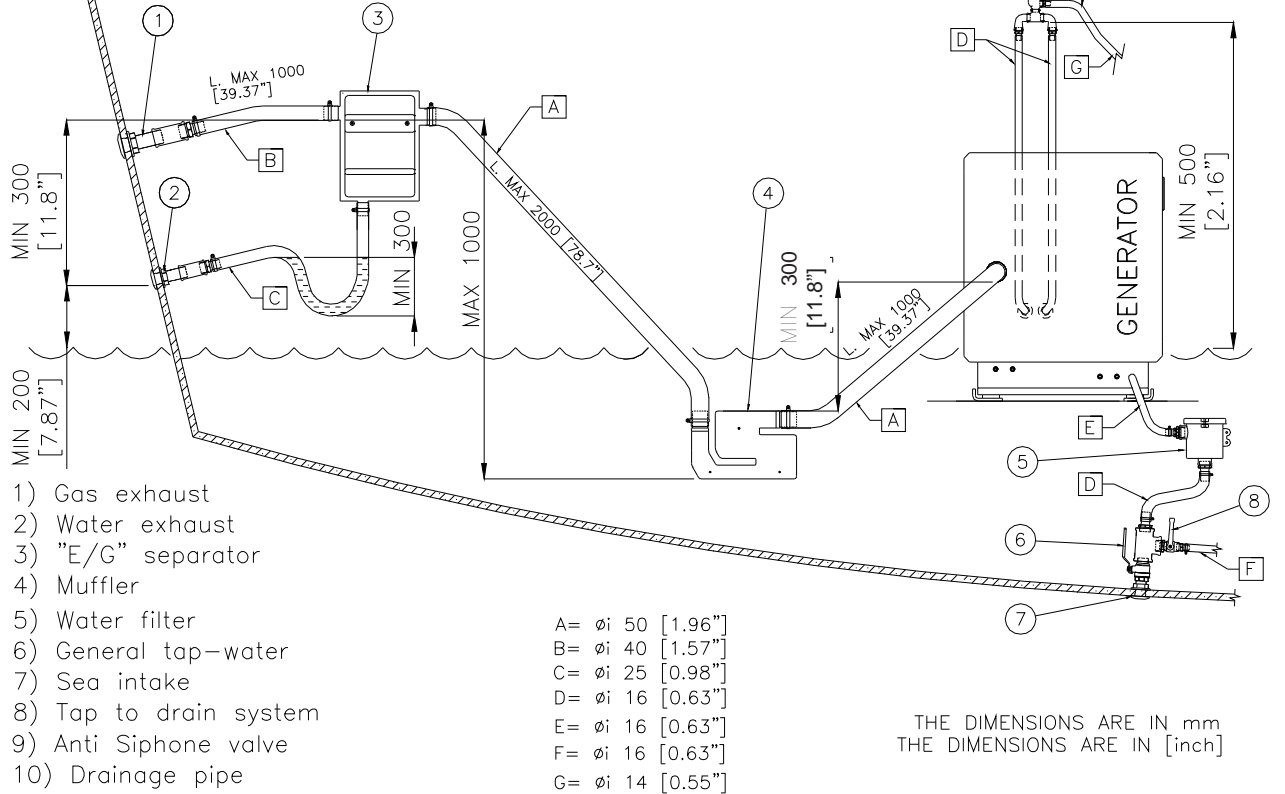

TYPICAL INSTALLATION WITH GENERATOR ABOVE THE WATERLINE WITH mase WATER/GAS SEPARATOR

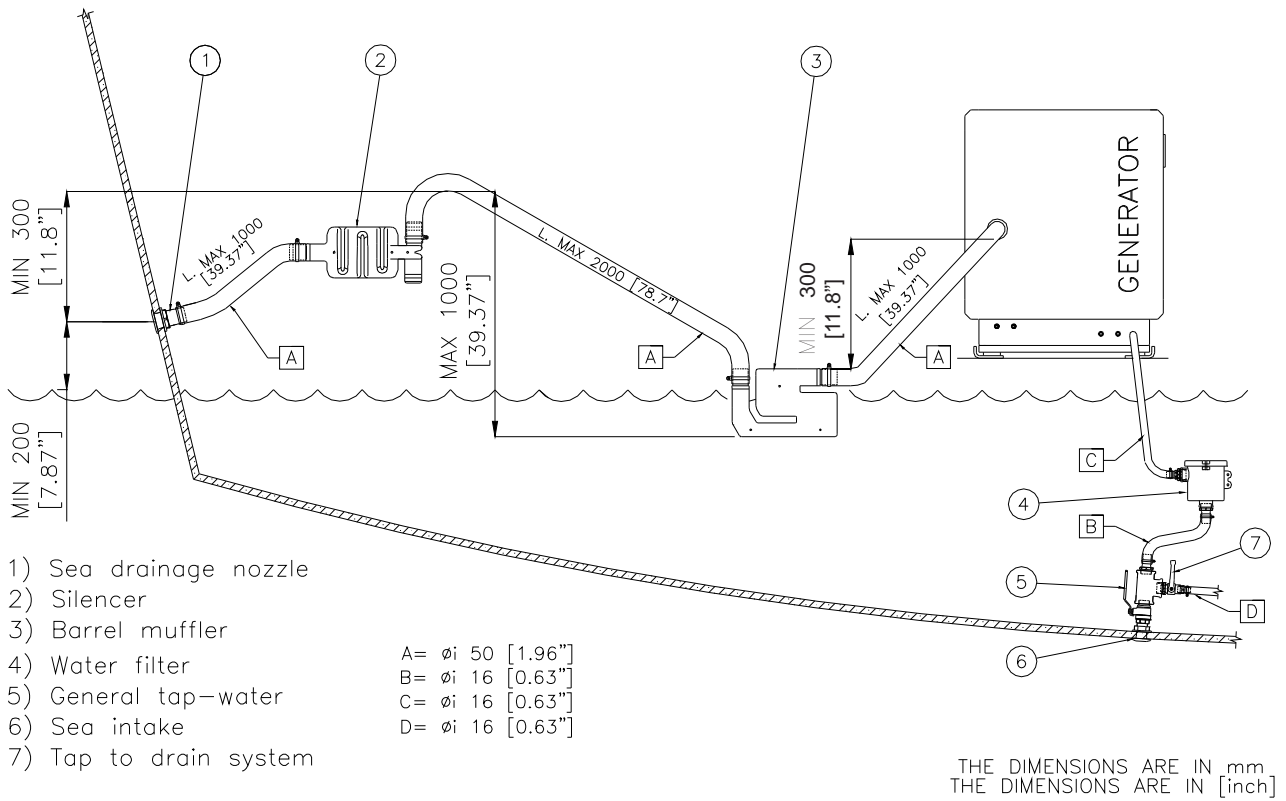

TYPICAL INSTALLATION WITH GENERATOR UNDER THE WATERLINE WITH mase WATER/GAS SEPARATOR

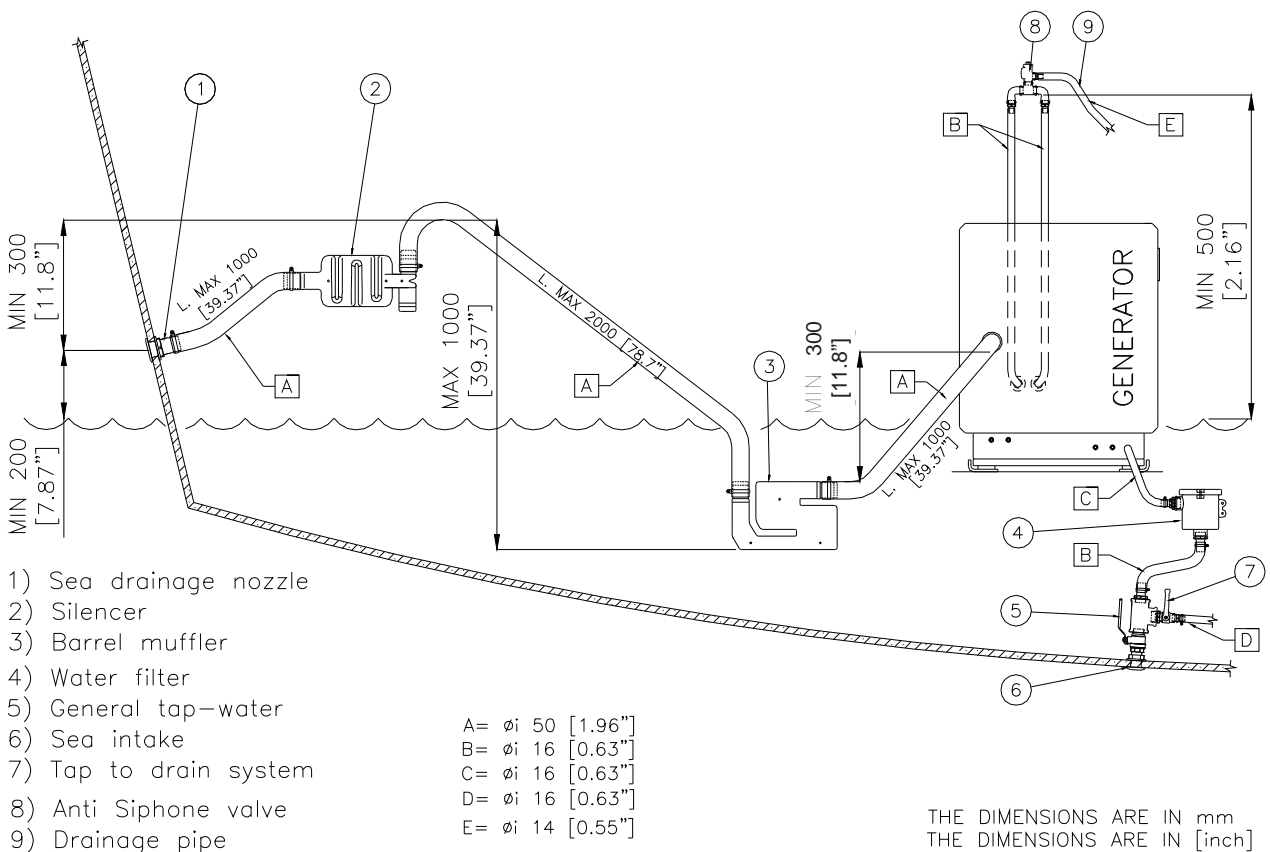

TYPICAL INSTALLATION WITH GENERATOR ABOVE THE WATERLINE WITH GENSEP WATER/GAS SEPARATOR

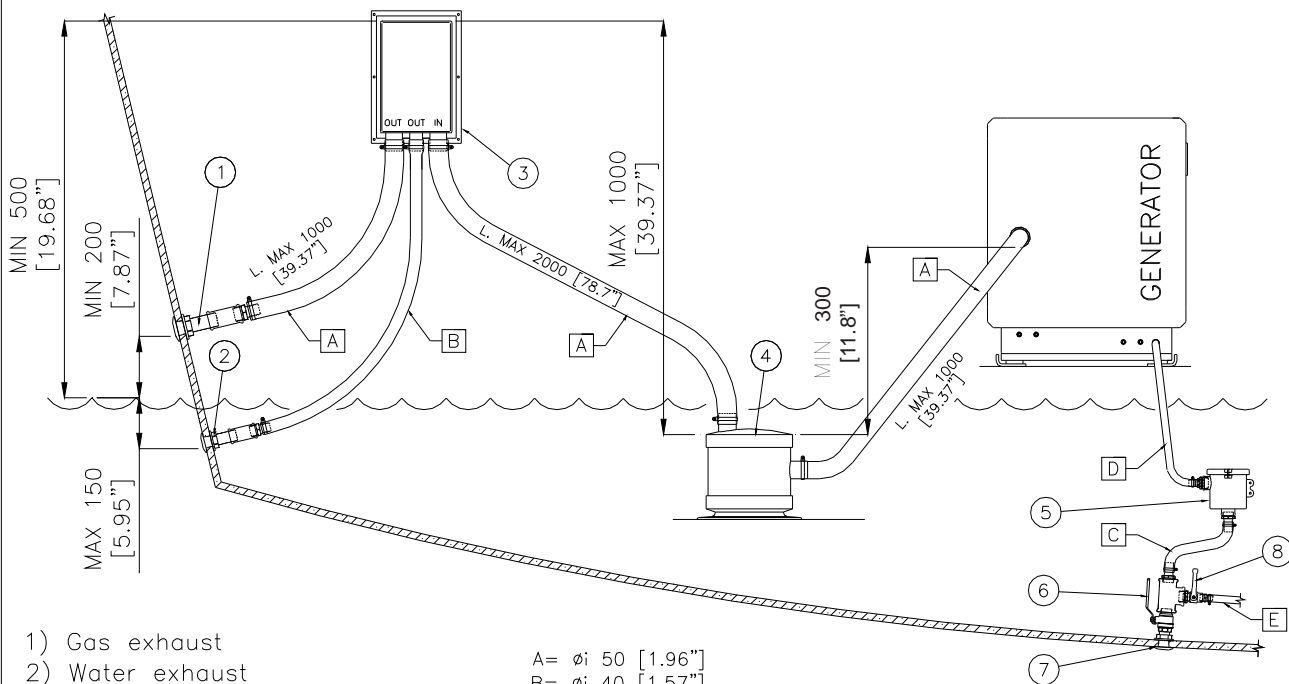

- 1) Gas exhaust
- 2) Water exhaust
- 3) Separator GENSEP
- 4) Muffler VERNALIFT
- 5) Water filter
- 6) General tap-water
- 7) Sea intake
- 8) Tap to drain system

- A= ϕ i 50 [1.96"]
- B= ϕ i 40 [1.57"]
- C= ϕ i 16 [0.63"]
- D= ϕ i 16 [0.63"]
- E= ϕ i 16 [0.63"]

THE DIMENSIONS ARE IN mm
THE DIMENSIONS ARE IN [inch]

TYPICAL INSTALLATION WITH GENERATOR UNDER THE WATERLINE WITH GENSEP WATER/GAS SEPARATOR

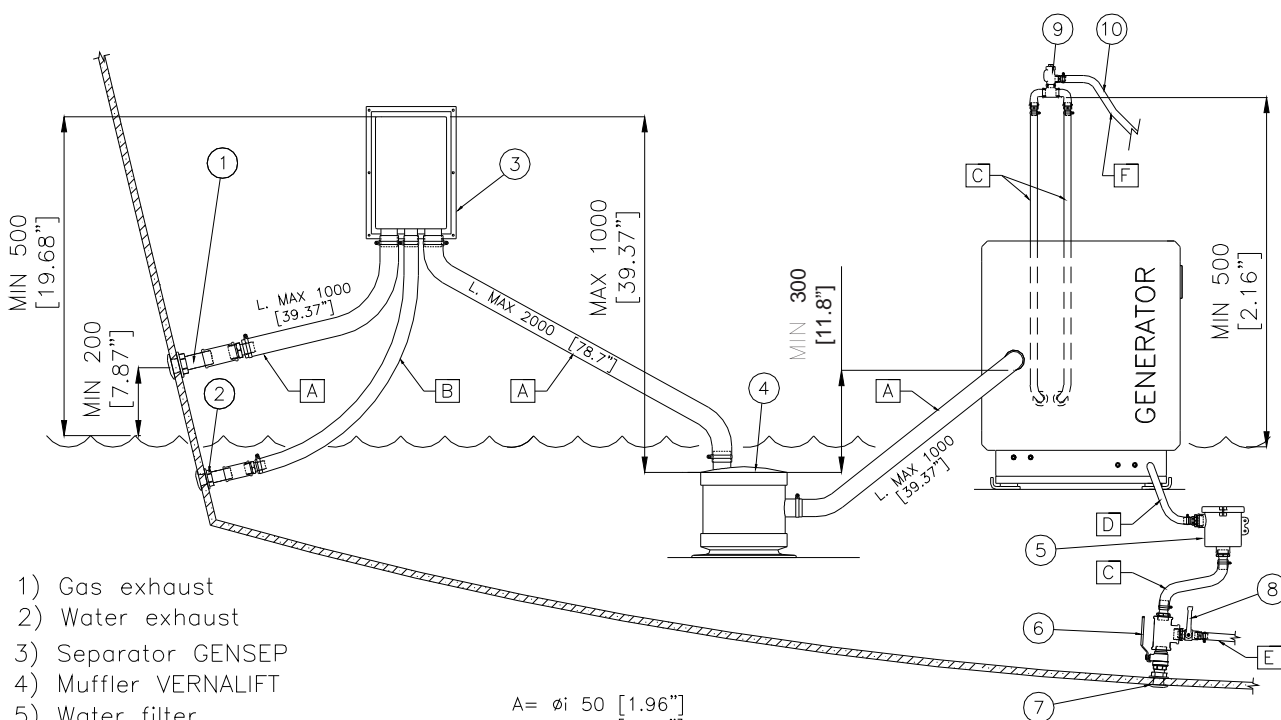

- 1) Gas exhaust
- 2) Water exhaust
- 3) Separator GENSEP
- 4) Muffler VERNALIFT
- 5) Water filter
- 6) General tap-water
- 7) Sea intake
- 8) Tap to drain system
- 9) Anti Siphon valve
- 10) Drainage pipe

- A= ϕ i 50 [1.96"]
- B= ϕ i 40 [1.57"]
- C= ϕ i 16 [0.63"]
- D= ϕ i 16 [0.63"]
- E= ϕ i 16 [0.63"]
- F= ϕ i 14 [0.55"]

THE DIMENSIONS ARE IN mm
THE DIMENSIONS ARE IN [inch]

3.5.4 EXHAUST SYSTEM

The generator combustion “gas/water exhaust” system must be independent of that of the main engines. See installation diagrams.

⚠ CAUTION

The pipe length from the highest point of the exhaust pipe to the exhaust must not exceed 2m (6.6 ft). This is to prevent that when the generator is switched off, the water that is left in the exhaust pipe flows back to the engine after having filled the barrel exhaust.

Barrel exhaust (capacity 3.5 litres - 0.92 gal).

Attenuates the exhaust noise and prevents water backflow to the engine. It is recommended to install the exhaust not more than 1m (3.3ft) from the generator and to position it at a height equal to or lower than that of the generator base.

Silencer

Further reduces the noise. It is recommended to install it at a distance of not more than 1m (3.3ft) from the sea exhaust union.

Sea exhaust union.

It must be installed in such a position that it is always above sea level.

Water/gas separator

Separates the water from the gas reducing the noise at the exhaust and eliminating the typical pulsating effect of water mixed with gas.



Carbon monoxide may cause strong nausea, fainting or death. Do not use copper pipes in diesel exhaust systems. The sulphur contained in diesel exhausts causes deterioration of the system leading to exhaust gas or water leaks.

Carbon monoxide may cause strong nausea, fainting or death.

For the safety of the boat occupants, install a carbon monoxide detector.

When installing the generator or carrying out maintenance operations, adopt the following precautions:

Do not install the exhaust gas outlet pipes in places where the gasses may be conveyed through the portholes, vents or air conditioning system. If the exhaust gas outlet is near the water level, water may enter the exhaust gas outlet and block or limit the gas flow.

GB

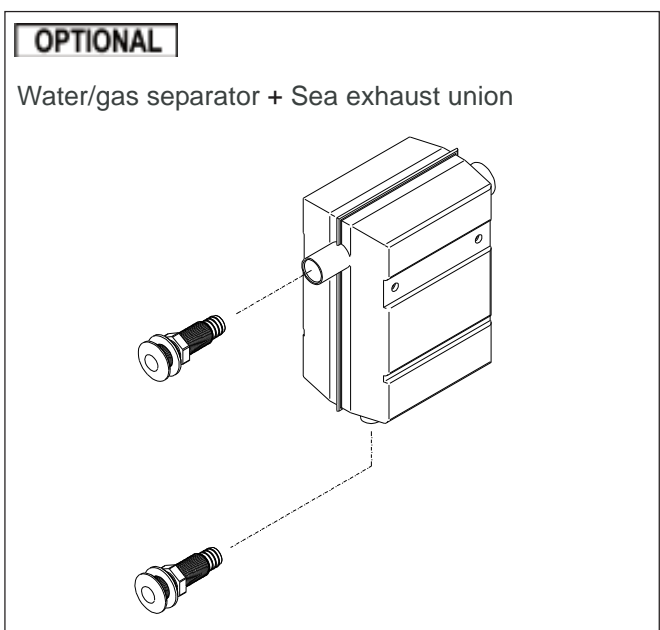
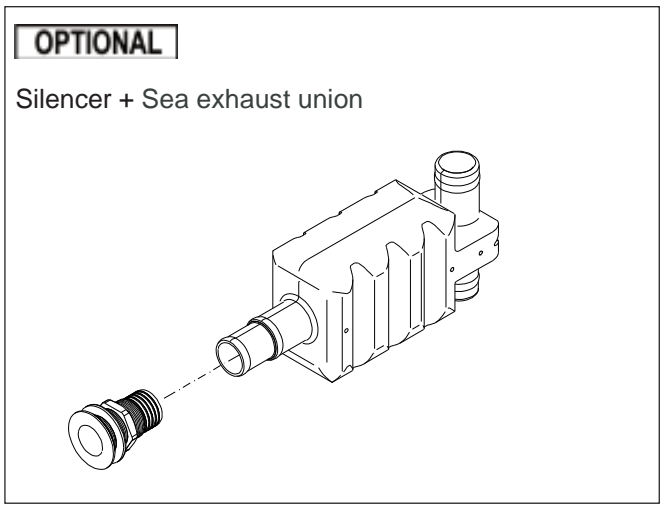
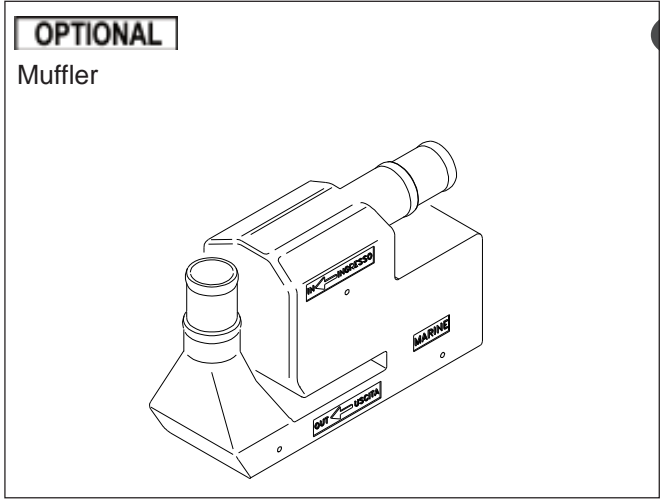

GB

3.6 FUEL CIRCUIT

The generator is diesel-powered by means of the unions marked "DIESEL FUEL INLET" (rif.1) e "DIESEL FUEL OUTLET" (rif.2); the latter serves to return excess fuel.

The fuel pipes must be in hydrocarbon-resistant rubber with an inside diameter of 8mm (0.31in). For differences in level of more than 500mm (19.6in), fit a single-acting check valve in order to prevent the fuel system from emptying out. Use a valve with 50mbar opening.

3.6.1 FUEL FILTER

The generating group is provided of fuel filter installed inside the genset.

3.6.2 WATER/FUEL SETTLER

The generating group is provided of water/fuel settler by **mase** non installed on board but furnished with it. Install it between tank and generating group. See ref.3.

⚠ CAUTION

Install the water/fuel settler obligatorily. Injection system could be seriously damaged if there is water mixed with fuel.

3.6.3 ELECTRIC PUMP

The electric pump is equipped with a protective filter (ref.4).

⚠ CAUTION

The electric pump is cooled and lubricated with the fuel. Do not activate the pump without fuel in order to not damage it.

I INFORMAZIONI

The feeding system has been developed for blow out, in autonomous way, the air beads penetrated inside the system. Activate the fuel pump for few minutes before starting the generator to have automatic bleeding.

To activate the fuel pump press the "START" button (ref.5) for a moment.

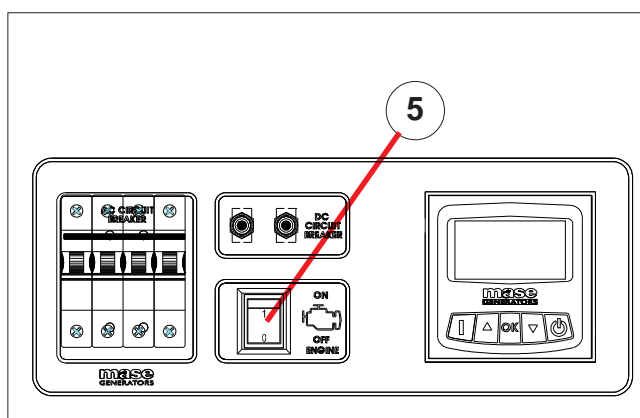
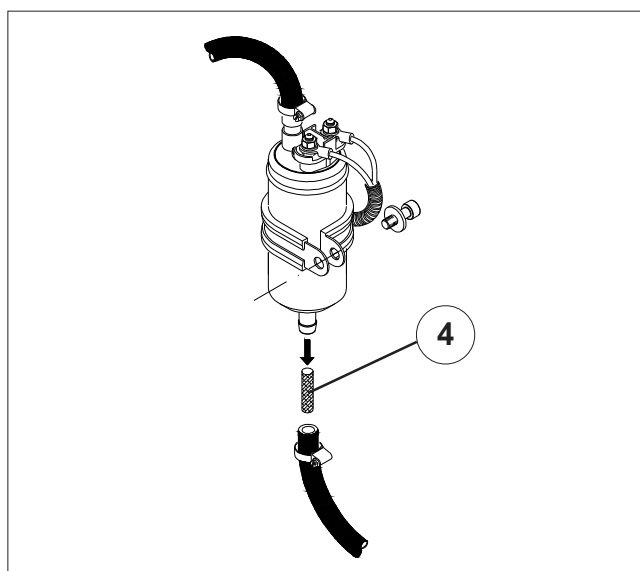
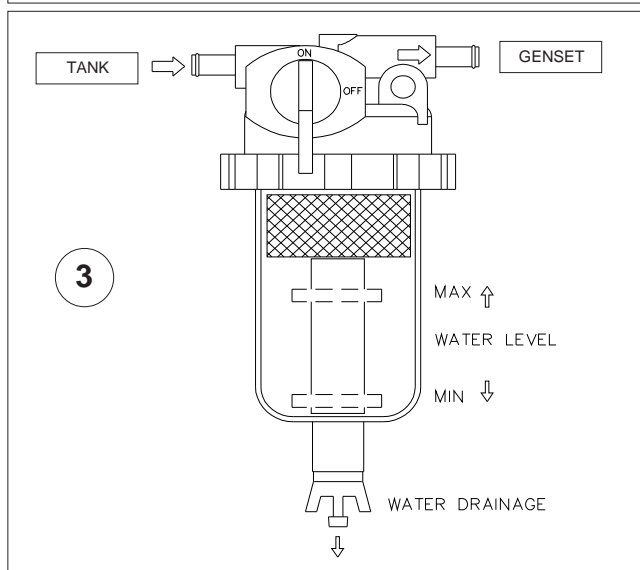
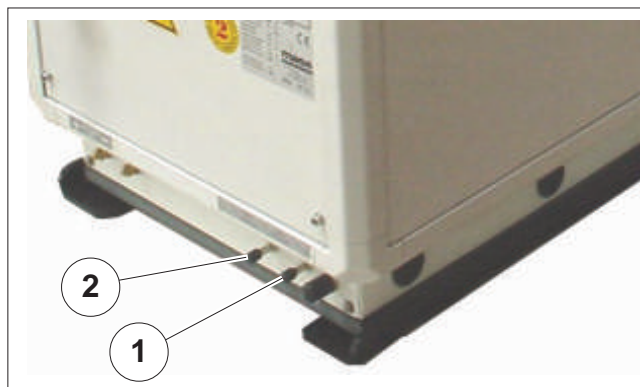

3.7 ELECTRICAL CONNECTIONS

3.7.1 BATTERY CONNECTION

Use a 12V stand-alone battery to start the generator. Connect it to the generator terminals using cables of 25mm² cross-section for a distance up to 5m (16.4ft) or cables of 35mm² cross-section for longer distances, following this sequence of operations:

- First connect the positive pole (+) of the battery to the terminal marked + on the generator (ref.1).
 - Then connect the negative pole (-) of the battery to the terminal marked - on the generator (ref.2).
 - Spread some specific mineral grease on the connectors in order to reduce oxidation or corrosion.
- The generator is equipped with an automatic electronic recharging device for the starter battery, able to deliver 40A at a voltage of 12V.



⚠ WARNING

Install the battery in a ventilated housing separate from the generator and any device which may cause heat or sparks. Periodically check the state of the terminal connections and the battery liquid level. If necessary, disconnect the cables working in reverse order from connection.

Do not invert the polarities of the connection cables, as the generator and the battery may be seriously damaged.

i INFORMATION

Do not connect any other loads to the battery. In order to minimise galvanic currents, the (-) of the generator battery must not be connected to the (-) of the other batteries on board.

3.7.2 REMOTE CONTROL PANEL CONNECTION

The generator can be connected with a connector to the remote starting panel (with 20 meters [80 inch] of cable), supplied by mase as an optional, and can be installed on the dashboard.

⚠ WARNING

When carrying out maintenance operations on the generator, disconnect the negative pole of the starter battery to prevent accidental starting.

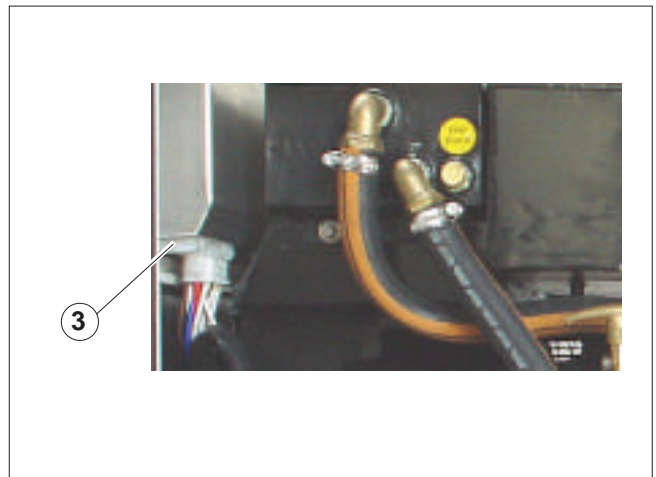
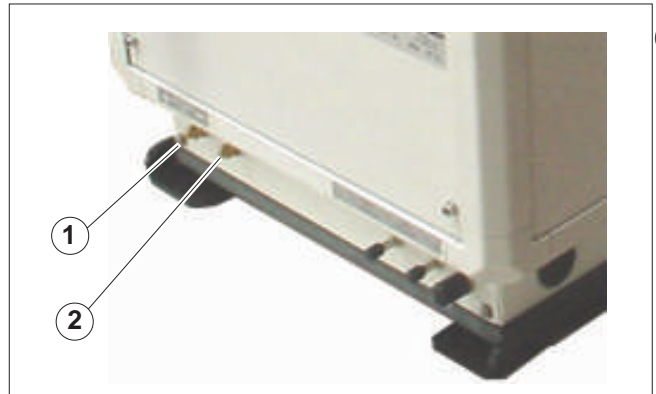

OPTIONAL

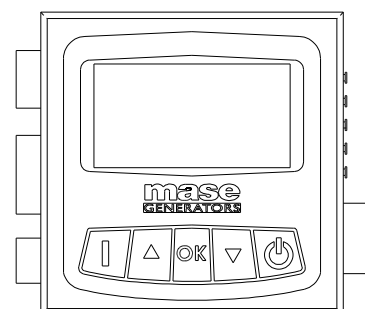
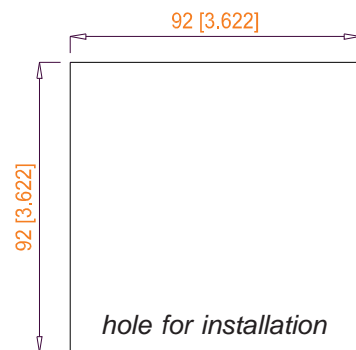

GB

3.7.3 A.C. CONNECTION

This connection can be made by means of the power terminal board.

**⚠ WARNING****Generator earthing.****High voltage may cause serious injury or death.**

Electroconduction is possible whenever electricity is present.

De-energise the main magnetothermal switches of all the power outputs before repairing the equipment. Configure the installation for earthing of the generator and the electrical circuits when in use.

Avoid contact with the electrical conductors or equipment when standing in water or on wet ground, since there is a higher risk of electroconduction in these conditions.

⚠ WARNING**Short-circuits. High voltage may cause serious injury or death.**

Short-circuits may cause physical injury and/or damage to the equipment. Avoid contact with the electrical connectors through tools or jewellery. Take off wrist watches, rings or any other jewellery before working on the electrical circuits.

⚠ WARNING**Feedback to utility. Feedback voltage may cause serious injury or death.**

Connect the generator to the electrical system of the structure/boat only through an approved electrical system and after opening the main switch of the structure/boat.

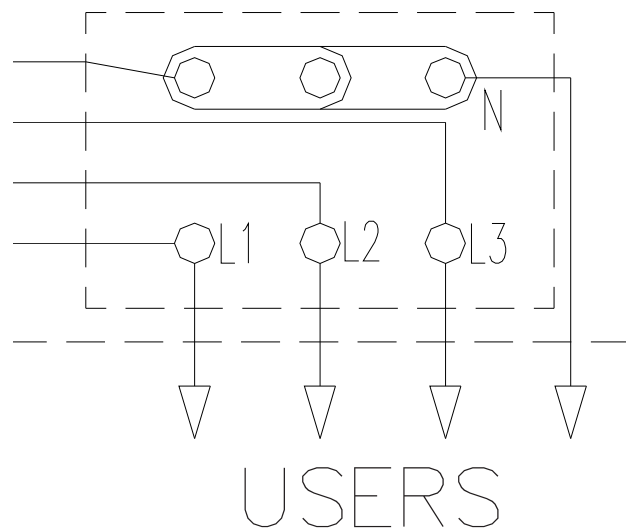

The feedback circuit may cause serious injury or death of the personnel working on the power lines and/or personnel near the working area.

- Make sure that the sum of the generator loads doesn't overcome the nominal power of the generator group.
- Despite the group is provided with a thermal switch (rif.1), it's recommend to interpose magnetothermal protections or similar between generator and electric users, according to the following table.

3.7.4 GENERATOR - NETWORK SWITCHING

A switch must be interposed on the utility line to allow switching the utilities from the generator to an external power supply line. The switch must be dimensioned on the basis of the entity of the loads involved;a broad diagram is shown in ref.2.

⚠ DANGER

*Do not connect the generator to a public electrical system (e.g. wharfs, ports, houses, other boats, etc.).
The feedback circuit may cause serious injury or death of the personnel working on the power lines and/or the personnel near the working area.*

⚠ DANGER

The generator may only be installed by qualified technicians. Malfunctioning due to improper installation may cause injury or death.

GB

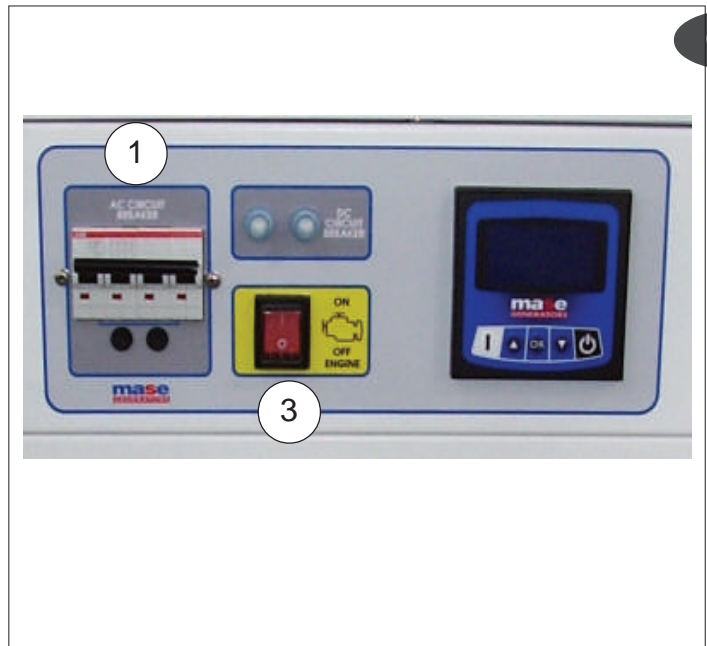

⚠ DANGER

Do not modify the default electrical connections for other applications. If necessary, contact our distributors.

3.7.5 EMERGENCY STOP

The generator can be stopped by setting the switch (ref.3) to the "OFF" position.

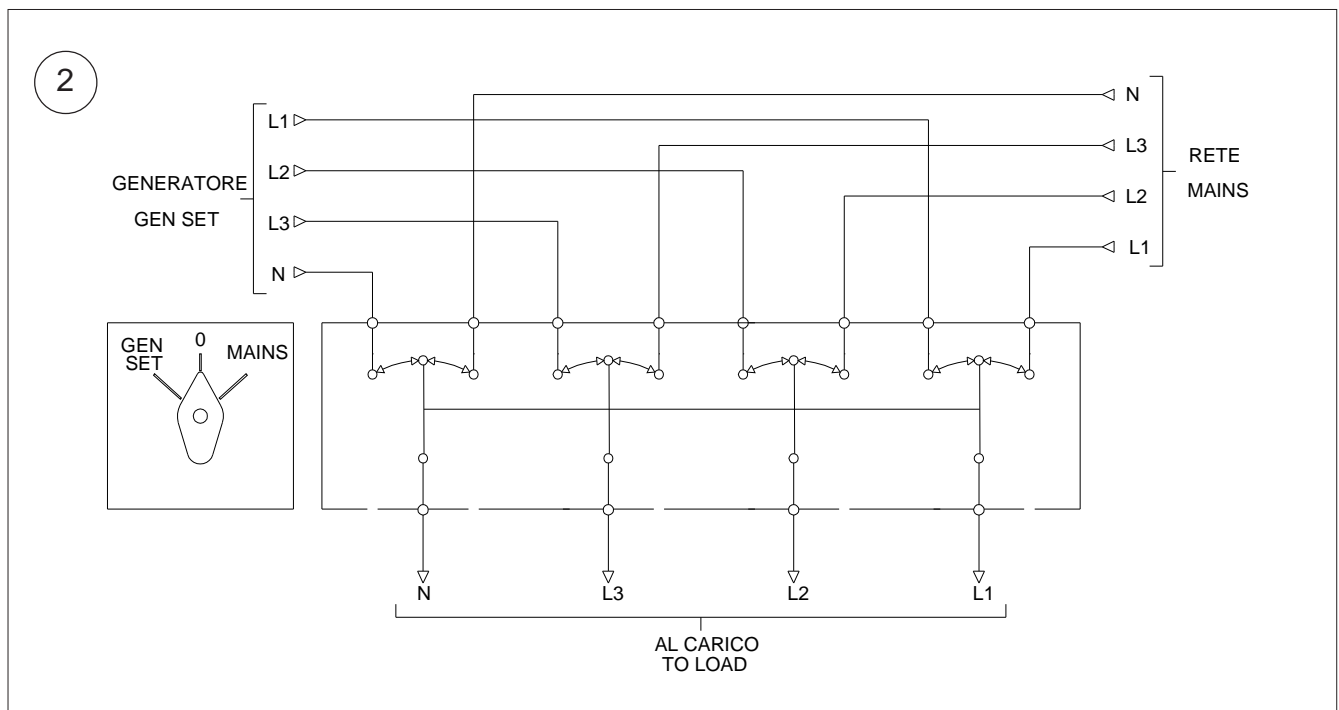

4 USING THE GENERATOR

4.1 PRELIMINARY CHECKS

Before beginning with any starting procedures, it is extremely important to “familiarise” yourself with the generator and its controls.

Furthermore, visually inspect the generator and the installation.

Any source of real or potential risk must be eliminated before proceeding.

- Identify the position of the emergency stop buttons, switches and other emergency systems on the generator.
- Learn the specific emergency procedures pertaining to the installation in question.
- Check the oil level by means of the dipstick (**ref. 1**). See table for recommended oils (**chap.6.4**)
- Check that all the anchoring points of the generator are properly tightened.
- Check that all the electrical utilities are off to prevent starting the generator on load.
- Check that the water and fuel pipes are properly connected
- Check that all the electrical connections have been properly made and that no connections are in a bad state.
- Check that the seawater cock is open (**ref. 2**)
- If a check valve has been fitted on the seawater intake (as recommended in the installation manual), check that the section of the water circuit leading from the pump to the valve has been manually primed (**ref.3**).

4.2 FUELLING

The fuelling operations must be carried out extremely carefully and the tank must not be filled over the maximum level.



- **Fuel is a toxic and flammable liquid, and must therefore be kept in hermetically sealed containers and stored in inaccessible places.**
- **Fuelling must always be carried out with the engine off and the selector in the OFF position.**
- **Do not smoke and do not use naked flames during fuelling.**
- **Fuel in well-ventilated places.**
- **Avoid contact of fuel with the skin and do not inhale the fumes.**

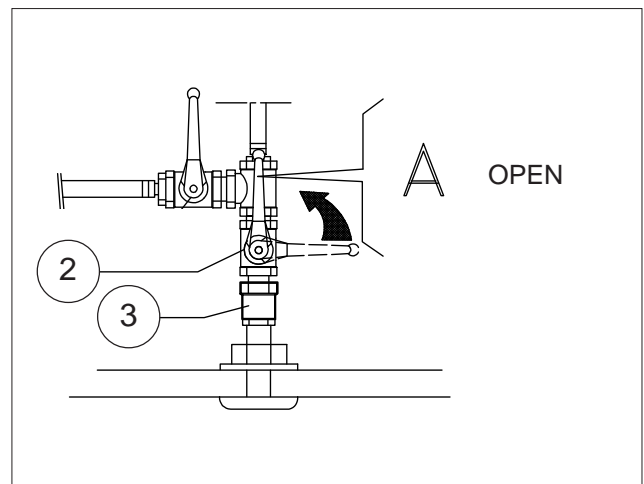
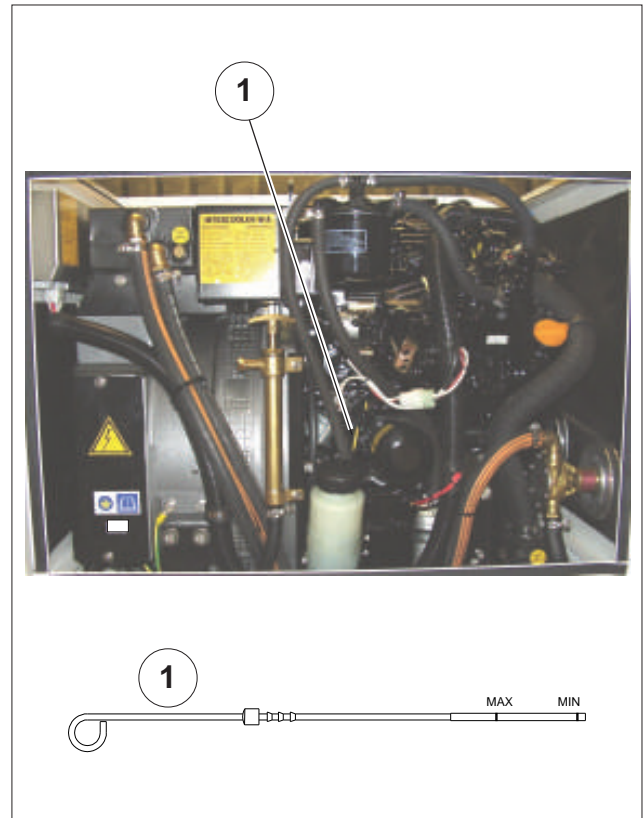

4.3 STARTING THE GENERATOR

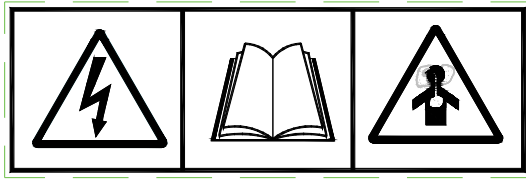

Before starting the generator check that all the doors are closed and the bipolar magnetothermal switch are open (ref.1).

Before starting the generator ensure that all the preliminary checks, described in paragraph 4.1, have been carried out. Proceed with starting as follow.

Start

Press the **ON/OFF** pushbutton (ref.2) to turn on the module. It will show "mase" logo on display.

Press and hold pressed the **START** pushbutton (ref.3) in

order to preheat the glow plugs (pre-starting) and then start the engine. Release only when the engine is started, paying attention to not exceed 5 seconds for each starting attempt and doing a pause of about 30 seconds between them. Press the remote **START** (if equipped with remote control), that controls the starter in the same mode as the start button on board module.

CAUTION

Repeated unsuccessful starting attempts may cause excessive accumulation of water in the exhaust system with possible serious damage to the engine.

Should you have difficulty in starting the engine, absolutely do not persist for a long time before first having closed the seawater intake cock (ref.5).

Do not make more than 5 consecutive starting attempts as you may damage the starter motor.

4.4 STOPPING THE GENERATING SET

Stop the generator by pressing the **STOP** button on the control panel (ref.2). The generator can be stopped also by setting the switch (ref.6) to the "0" position.

Press the remote **STOP** (if equipped with remote control),

for stopping generator in the same mode as the onboard module **STOP** button.

CAUTION

Before stopping the generator, it is advisable to run it for a few minutes without drawing current in order to allow gradual cooling of engine and alternator.

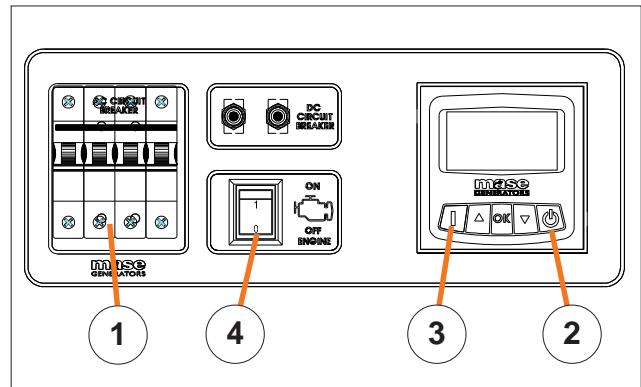

GB

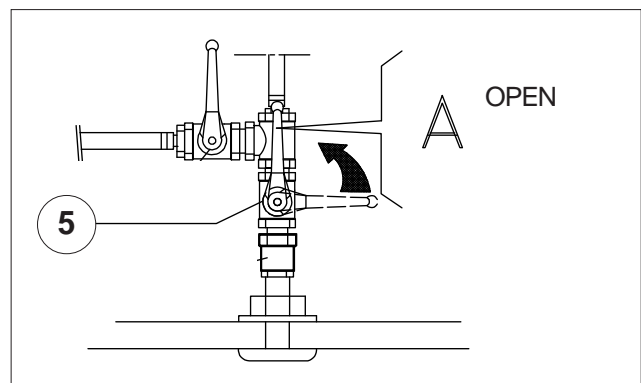

4.5 EMERGENCY STOP

For an emergency stop (ref.6) of the generator, set the emergency switch to "0".

Once the causes that determined the need for an emergency stop have been eliminated, reset the emergency switch to "1" to return to the operating conditions.

5 PROTECTIONS AND WARNING SIGNALS

5.1 ENGINE PROTECTION MODULE

CBU device (Can-Bus transmission unit) controls and driving the genset.

Large display and the control push-buttons allow an easy use and monitoring of the CBU unit.

Displayed information

- Voltage Vac
- Frequency Hz
- Hourmeter
- Battery voltage of the genset
- Voltage of onboard batteries
- Low oil pressure alarm
- High engine temperature alarm
- High alternator temperature alarm
- Engine preheating
- Stop alarms
- Storage and back-up of alarms
- Maintenance warning (first 50 hours)

Input / Output signals - Commands - Checks

- Connector mod. 485 for MODBUS protocol. (It allows monitoring and driving the genset by the boat main control monitor)
- Output all included alarms (optional)
- Input battery voltage of the genset
- Input Start/Stop from remote panel
- Switch off button
- Scroll through display buttons
- Several possible modules in parallel mode connection (1 onboard + 1 on remote panel)
- Emergency push button (predisposition)

⚠ CAUTION

The low oil pressure protection does not give an indication of the oil level.

The oil level must daily be checked in order to prevent damage to the engine.

⚠ CAUTION

The engine correctly works if it doesn't exceed inclinations max of 30° for up to 3 minutes and 25° without limits of time, in comparison to both longitudinal and transversal axles. If the engine works to greater inclinations, it risks an insufficient lubrication and/or aspiration of oil from the filter air.

Alarm code	Symbol	Alarm name	Description
0		Emergency stop	Means that the emergency pushbutton is pressed.
2		Alternator failure c.b. D+	If enable, means that battery charger alternator is not detected at engine running D+
3		Missing engine stop	Means that, after engine is stopped, the electronic board detects active parameters as the engine is still running.
4		Mechanical failure	If generator is running, means that all detected parameters are simultaneously missing.
9		Pre-alarm analog temperature	Means that the detected temperature by analog sensor rised up over the setted pre-alarm limit.
10		High engine analog temperature	Means that the detected temperature by analog sensor rised up over the setted alarm limit.
12		Pre-alarm analog oil pressure	Means that the detected oil pressure by analog sensor is lower than the setted pre-alarm limit.
13		Analog low pressure oil	Means that the detected oil pressure by analog sensor is lower than the setted alarm limit.
16		High level battery	Means that the battery voltage is too high.
17		Low level battery	Means that the battery voltage is too low.
20		Generator: low frequency	Means that the generator frequency is too low.
21		Generator: high frequency	Means that the generator frequency is too high.
22		Generator: low voltage	Means that the generator vottage is lower than the setted alarm threshold.
23		Generator: high voltage	Means that the generator vottage is higher than the setted alarm threshold.
24		Alternator high temperature	Manse that the high engine temperature contact is open.

5.2 PROTECTION AGAINST SHORT-CIRCUITS AND OVERLOAD

The generator is protected against short-circuits and electrical overload.

A magnetothermal switch cuts off the electrical current when a short-circuit occurs or when the current delivered exceeds the rated value

WARNING

Before restoring the current delivery remove the cause of the cut off, then disconnect the loads and restore the magnetothermal switch on "ON" position.

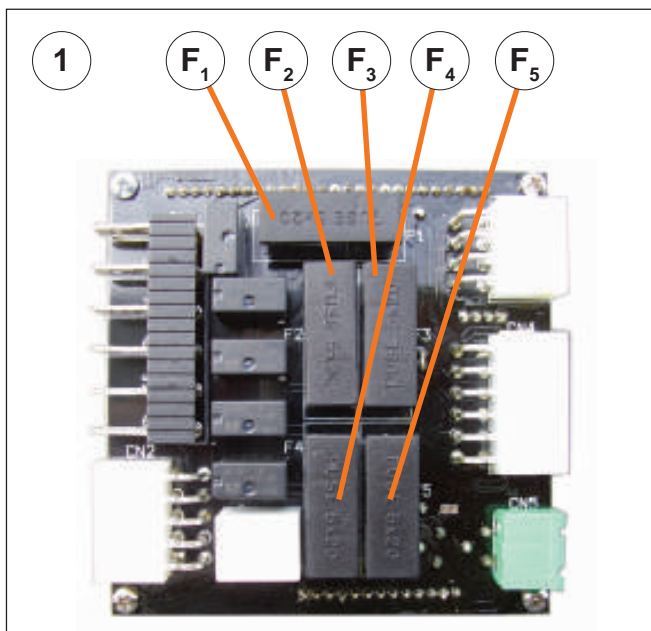

5.3 PROTECTION AGAINST SHORT-CIRCUITS OF LOW-VOLTAGE ELECTRICAL SYSTEM.

The low voltage electric plant is protected by 2 thermal switch, they shutdown the generator set.

The first thermal switch stops the generator set, turns off all the alarm light and prevents the starting.

The second thermal switch stops the generator set when there is a stop electromagnet failure on the generator set.

N.B. It does not prevent the START command, the alarm lights are active. Press the thermal switch to restore the contact.

5.4 FUSES

- Protection module fuses

On the printed circuit of the engine protection module there are five fuses (**ref.1**) to protect the module.

Remove the frontal panel unscrewing the 4 screws to enter in it.

F₁ : 5A 5x20mm for relay "ALARMS"

F₂ : 5A 5x20mm for relay "IP" (insulated poles)

F₃ : 5A 5x20mm for relay "RUNS"

F₄ : 5A 5x20mm for relay "GLOWS"

F₅ : 5A 5x20mm for relay "EV" (solenoid)

6 MAINTENANCE

6.1 PREAMBLE

It is recommended to strictly follow the instructions in the manual provided by the engine manufacturer, which accompanies each generator.

It is important to regularly check and carry out maintenance on the generator. The operations to carry out must be decided based on the hours of operation.

In order to carry out maintenance, the side doors and top door must be removed.

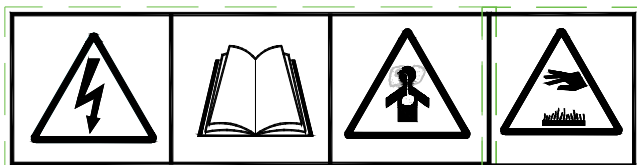
**⚠ WARNING**

The generator is started from a remote control panel. In order to prevent accidental starting, set the emergency switch to the (OFF) position. Disconnect the negative pole from the starter battery.

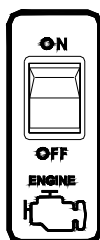
**⚠ WARNING**

Any maintenance operation on the generator must be carried out with the engine off, after leaving it to cool down sufficiently.

Carefully read paragraph 1.5 "General danger information" in the manual. Periodically check the electrical safety switches, such as the emergency button, the earthing system, etc.

6.2 ROUTINE ENGINE MAINTENANCE

The periodic operations to be carried out on the engine are indicated in the table "Service schedule" in paragraph 6.21.

For more detailed information, consult the manual provided by the engine manufacturer, which accompanies each generator.

6.3 ENGINE OIL CHECK

- Check the oil level by means of the cap/dipstick (**ref.1**). The oil level must always be between the MAX and MIN notches engraved on the dipstick.
- When checking the oil level, ensure that the generator is positioned horizontally.

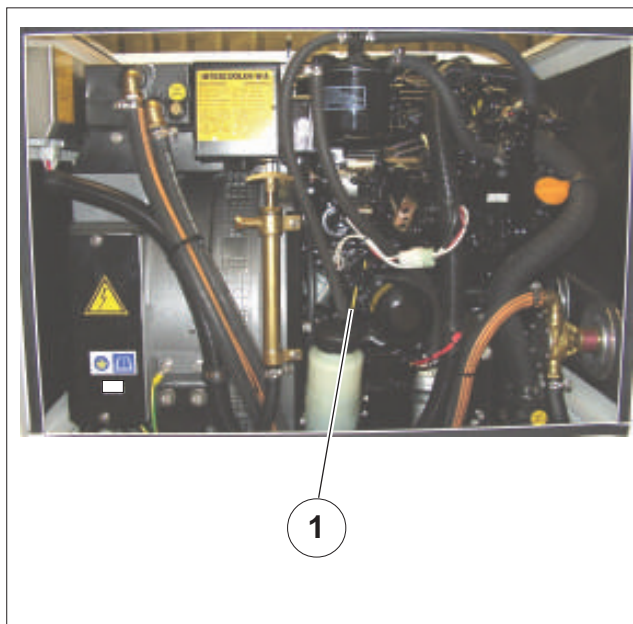

6.4 ENGINE OIL CHANGE ✂

Use diesel engine oil

Top up the engine oil through the hole (ref.1). To change the oil in the engine oil sump, take out the dipstick (ref.2) and operate the extraction pump (ref.3) after removing the screw that acts as cap.

It is advisable to drain the oil when it is still sufficiently warm so that it flows easily.

CAUTION

- *Dispose of the used oil in an appropriate manner, since it is a polluting product.*
- *Take the used oil to special waste collection centres for disposal.*
- *Wear gloves to protect the hands from contact with oil. In case of accidental contact with engine oil, thoroughly wash the affected part with soap and water.*
- *Do not top-up with oil or refuel above the maximum level. An excessive quantity of oil may cause damage to the engine.*

INFORMATION

Always check proper viscosity of the engine oil in relation to the range of temperatures in which the generator operates, as indicated in chap 6.5.

6.5 OIL FILTER ✂

To replace the engine oil filter cartridge, follow the procedure below:

- Remove and extract the filter (ref.4).
- Screw in the new filter after cleaning the rubber seal and seating surface and ensure it is in perfect condition.

CAUTION

When the operation has been completed, thoroughly clean all the parts of the generator soiled with oil and fuel.

INFORMATION

For engine safety reasons, use only original spare parts.

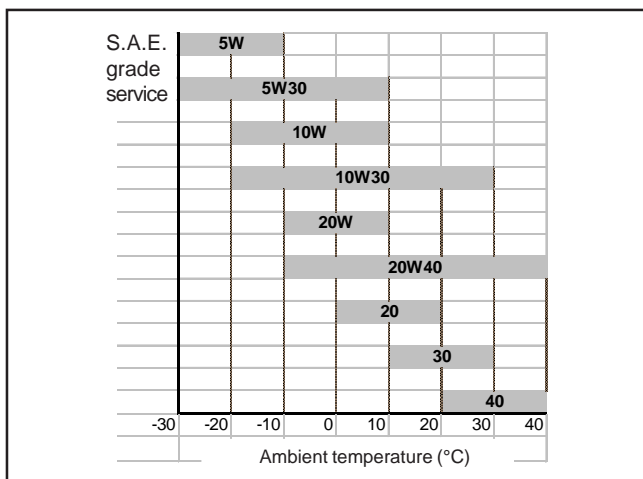
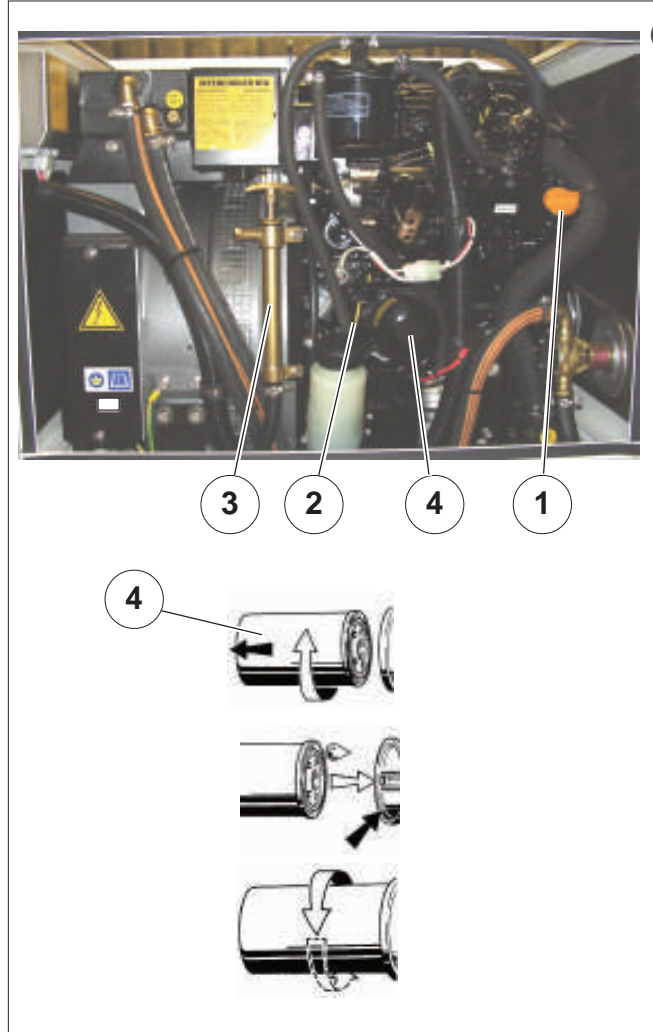

GB

6.6 REPLACING / CLEANING THE FUEL PUMP FILTER

This operation is carried out following the steps below:

- Remove the pipe (**ref.1**)
- Slide out the filter (**ref.2**)
- Clean or replace it

For reassembly repeat the operations in reverse order.
After replacing the filter, the fuel system has to be bled by carrying out the operations described in **par 6.10**.

6.7 REPLACING THE LINE FUEL FILTER

This operation is carried out following the steps below:

- Close the fuel faucet (**ref.3**)
- Unscrew the support ferrule (**ref.4**) completely
- Remove the old cartridge and replace with a new one.

For reassembly repeat the operations in reverse order.

6.8 DRAINING OF THE OIL/WATER SEPARATOR

Drain off the oil/water separator whenever there is a lot of drain collected in the oil/water separator at the bottom of the cup even if not the time for periodic inspection hour.
The cup of the oil/water separator is made from semitransparency material and in the cup, the red colored float ring which rises on the surface of the drain is installed to visualize the amount of drain.

Drain off the oil/water separator in the following manner:

- 1) Prepare a waste oil container
- 2) Close the fuel cock (**ref.5**)
- 3) Loosen the drain cock at the bottom of the oil/water separator (**ref.6**), and drain off any water collected inside.
- 4) Tighten the drain cock with hand.
- 5) Be sure to bleed air in the fuel system.

6.9 CLEANING OIL/WATER SEPARATOR

Periodically wash the oil/water separator element and inside cup with clean fuel oil.

- 1) Prepare a waste fuel container
- 2) Close the fuel cock (**ref.5**)
- 3) Loosen the drain cock (**ref.6**) and drain
- 4) Turn the retaining ring (**ref.7**) counter-clockwise and remove the cup (**ref.8**). (Keep the float ring (**ref.9**) at hand).
- 5) Wash the element and inside cup with clean fuel oil.
Replace the element with new one if any damaged.

⚠ WARNING

Do not let the skin come into contact with the fuel. During maintenance operations wear protective gloves and glasses.

In the event of accidental contact with fuel, thoroughly and immediately wash the affected part with soap and water.

When the operation has been completed, thoroughly clean off any traces of fuel and dispose of the used cloths at special Collection Centres.

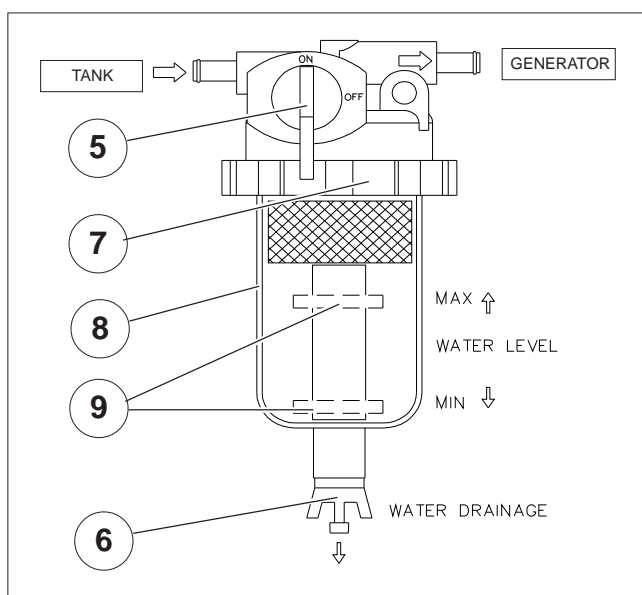
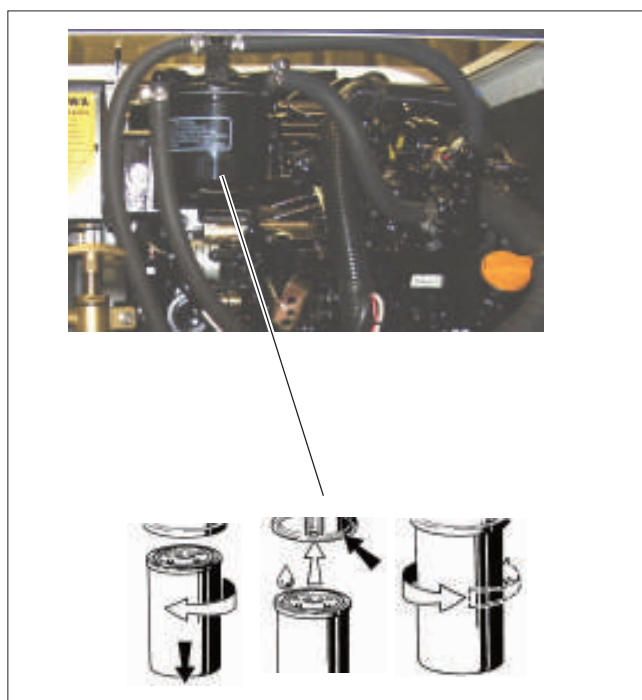
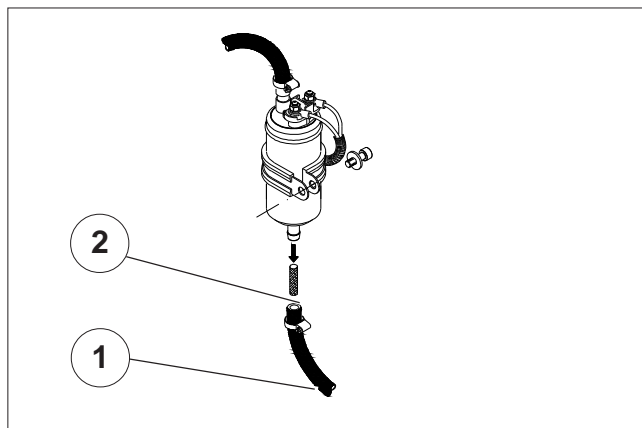

6.10 BLEEDING THE FUEL SYSTEM

I INFORMATION

The fuel system is developed to eliminate, in autonomous way, air bubbles penetrated inside the system. For automatic bleeding activate the fuel pump for few minutes before starting the engine. To activate the fuel pump press for a moment the "START" button (ref.1).

For the manual bleeding activate the fuel pump and loosen the screw (ref.2).

If there are air bubbles in the fuel system, the engine will not function regularly or will be unable to reach the rated rpm. Air may penetrate the fuel circuit through a not perfectly sealed joint (pipe, filters, tank) or when the fuel in the tank is at minimum level.

6.11 AIR FILTER

The IS series generators are fitted with a dry air filter (ref.3), which prevents foreign bodies from entering the combustion chamber. It is sufficient to clean the filter mass with diesel fuel once a year to remove any impurities.

⚠ CAUTION

Take the liquids used to wash the filter to special waste collection centres for disposal.

6.12 DRAINING THE COOLING SYSTEM

In order to carry out maintenance on the exchangers and the cooling system, the seawater circuit must be drained.

Carry out this operation as follows:

- close the seawater intake cock (ref.4);
- open the drain tap (ref.5) until all the water has completely drained out;
- remove the cap (ref.6) and make the water draining from water/water exchanger.
- close the drain tap.

⚠ CAUTION

Reopen the seawater intake cock before starting the generator.

6.13 REPLACING THE ZINC ANODE

A sacrificial zinc anode (ref.9-10) has been fitted in the heat exchangers (ref.7-8) to protect them against galvanic currents.

Periodically check the state of wear and replace it if necessary, in order to prevent galvanic currents from irreparably corroding the exchanger. It is recommended to check the zinc anode at least once a month when the generator is new in order to check how fast it wears, and then act accordingly.

It is in any case advisable to replace the zinc anode at least once a year.

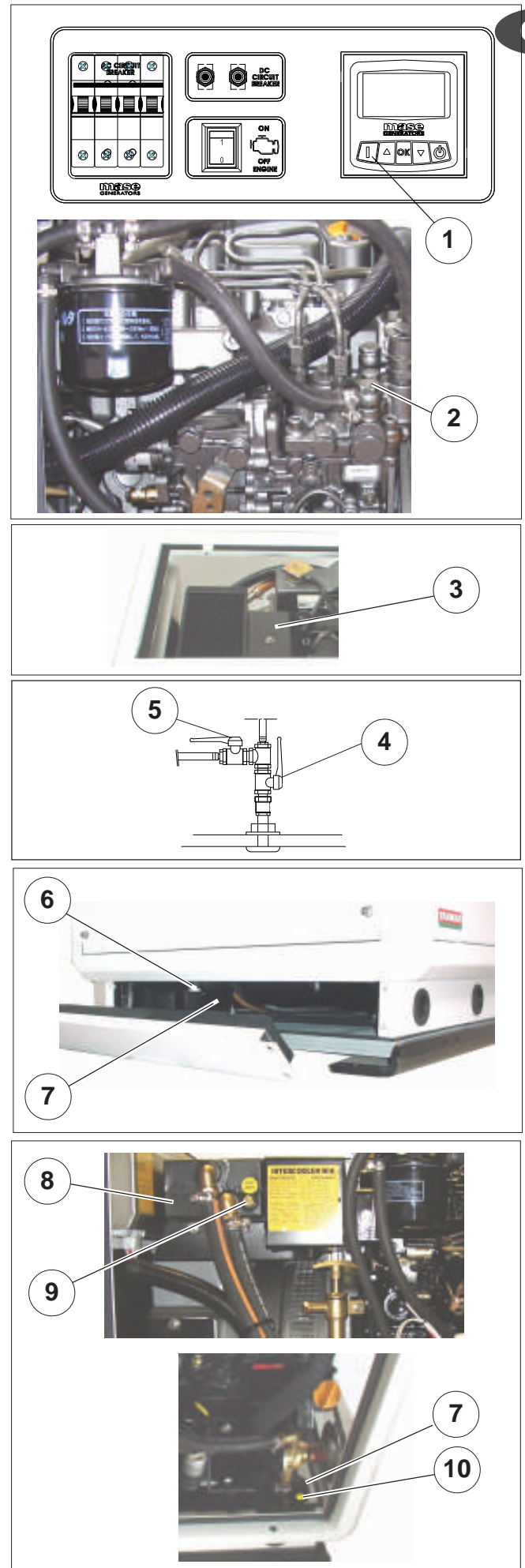

GB

6.14 SEAWATER PUMP MAINTENANCE

At least once a year check the integrity of the rubber seawater pump impeller.

Before opening the seawater pump to inspect the impeller, drain the seawater from the cooling system as described in **paragraph 6.12**.

To access the impeller, remove the cover (**ref.5**) and use pliers to extract the impeller (**ref.6**), pulling it hard towards the outside.

To refit a new impeller, repeat the operations described above working in reverse order.

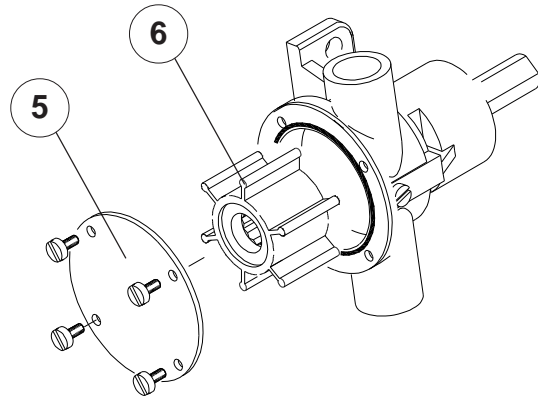

6.15 CHECKING / REPLACING THE V-BELT ✂

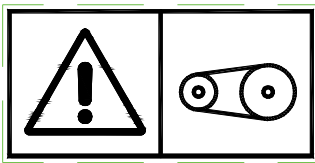

WARNING

Do not open the doors or hold the hands close to the V-belts and pulleys when the engine is running.

A V-belt is used to transmit the rotation motion from the drive shaft pulley to the seawater pump pulley (**ref.1**). A too tight belt accelerates wear, while a too slack belt results in the pulleys running in idle and insufficient water circulation.

Adjust the belt tension as follows:

Loosen the two adjusting screws (**ref.2**) and move the seawater pump towards the outside to increase tension or towards the inside to decrease it. Tighten the screws and check the tension.

The belt tension is correct when it sags about 5mm (**ref.3**) under a thrust force of 8kg (17,7lbs).

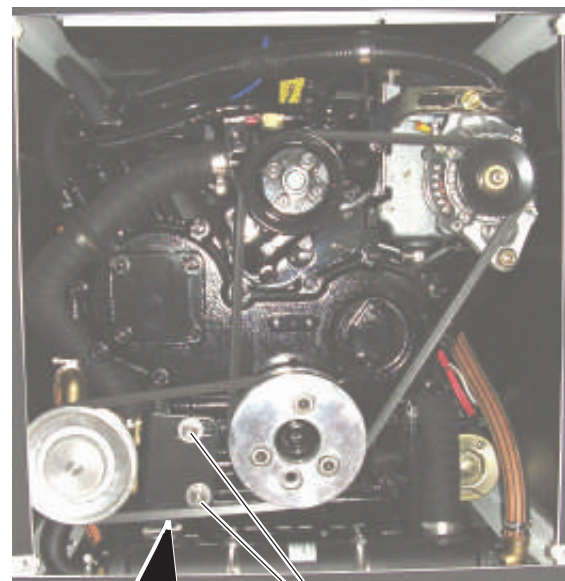

3

2

8Kg - 5mm

6.16 CHECKING / REPLACING THE ALTERNATOR V-BELT ✂

A second belt is used to transmit the rotary motion from the drive shaft pulley to that of the closed-circuit coolant pump and the battery charger DC alternator (rif.1).

Adjust the belt tension as follows:

Loosen the adjusting screw (rif.2) and move the battery charger DC alternator outwards to increase the tension and inwards to decrease it.

The correct belt tension is such as to allow a yield of about 10 mm (rif.3) under a thrust force of 8kg (17,7lbs).

⚠ DANGER *Keep hands away from the V-belt or the pulleys when the engine is running.*

6.17 ALTERNATOR MAINTENANCE

The alternator used on this model generator is type synchronous, self-excited. This type of brushless alternator without manifold does not require any particular maintenance.

Periodic inspections and maintenance are limited to eliminating any traces of moisture and oxidation which may damage it.

6.18 BATTERY MAINTENANCE



Before installing a new battery, it is important that it first be fully recharged.

⚠ WARNING

Have the battery activated by personnel who have sulphuric acid for batteries and suitable equipment available.

At least once a month check the level of the electrolyte and, if necessary, top up with distilled water. If the generator is not used for a long period of time, it is advisable to disconnect it and store it in a dry place at a temperature above 10°C (50°F), and to carry out a full recharging cycle once a month.

⚠ WARNING

When topping up the batteries with distilled water, wear rubber gloves and protective goggles to prevent accidental contact of sulphuric acid with the skin. In the event of accidental contact, thoroughly wash the affected part with soap and water and consult a doctor.

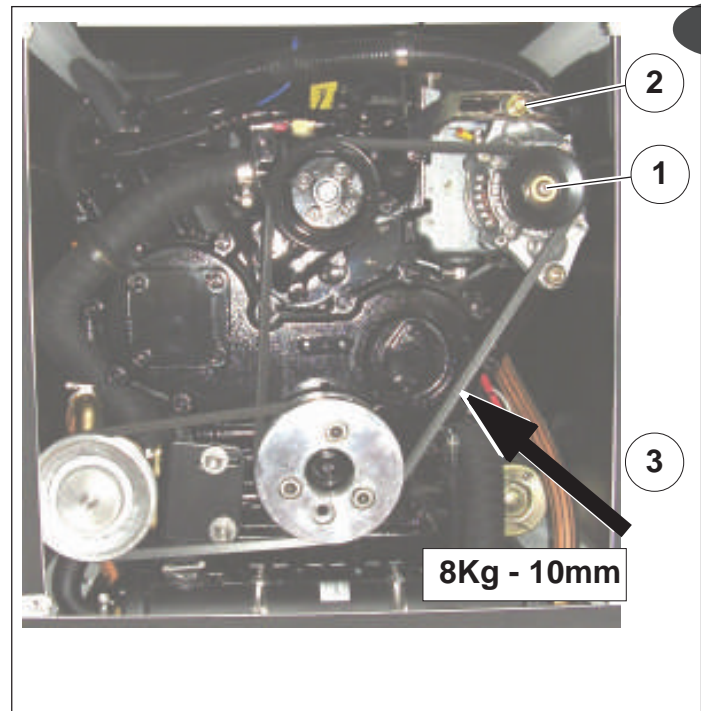

⚠ CAUTION

If the battery is left completely flat for long periods of time, it may be irreparably damaged.

i INFORMATION

Before proceeding with recharging the batteries, check the level of electrolyte and, if necessary, top up with distilled water. This operation must be repeated when the charging cycle has been completed. Cover the positive terminal with Vaseline to protect it against corrosion and the formation of oxide.

6.19 LIST OF RECOMMENDED SPARE PARTS

Description
Seawater pump impeller
Seawater pump gasket
Seawater pump belt
Oil filter
Fuel filter
Zinc anode
Fuses

OPTIONAL

A kit with recommended spare parts is available and may be ordered from the Mase Service Network or Technical Service.

6.20 PERIODS OF INACTIVITY ✂

Start up the generator at least once a month. If the generator is not to be used for a long period of time, carry out the following operations:

- Change the engine oil.
- Replace the oil filter cartridge (see **par.6.5**).
- Replace the fuel filter cartridge (see **par.6.6, 6.7**).
- Remove the injector and pour 2 cc of engine oil into the cylinder and let the engine turn a few times by manually operating the drive shaft pulley.
Refit the injector.
- Replace the zinc pads (see **par.6.13**)
- Aspirate some antifreeze into the seawater intake pipe in order to protect the exchangers against low temperatures, and lubricate the seawater pump impeller and the metal parts in the cooling system.
- Disconnect the starter battery and store it in a dry place (see **par. 6.15**)
- Disconnect the sea exhaust pipe from the engine manifold.
- Clean the seawater filter.
- Close the seawater intake cock.
- Drain the seawater from the exhaust.
- Clean and lubricate the antisiphon valve (siphon break), if installed.
- Clean the outside of the generator, removing all dust and impurities.
- Cover the generator with a nylon sheet and store it in horizontal position in a dry and ventilated place.

6.21 PERIOD CHECKS AND MAINTENANCE

Perform service at intervals indicated	Before starting	Every 50 hrs.or 1 Month	Every 200 hrs.or 3 Month	Every 400 hrs.or 6 Month	Every 500 hrs.or Yearly	Every 1000 hrs.or Yearly	Every 2000 hrs.or Yearly
Fuel system							
Check the fuel level and refill	○						
Remove sediment from fuel tank		○					
Water/fuel separator drainage		○					
Clean the water/fuel separator					○		
Replace the fuel filter element					○		
Check the fuel injection nozzle						○	
Check the fuel injection timing							●
Check the fuel injection pump							●
Lubrication system							
Check the oil level	○ (Before operation)						
Replace the oil		○ 1 st time	○ (and thereafter)				
Replace the oil filter element		○ 1 st time	○ (and thereafter)				
Cooling system							
Check and eventually add the liquid cooling	○						
Replace the the liquid cooling						○	
Inspect exhaust system components for cracks and corrosion (exhaust line, hose clamps, silencer and outlet flapper)	○						
Check function of siphon break (if equipped)		○	○				
Adjust seawater pump belt tension		○ 1 st time	○ (and thereafter)				
Replace seawater pump impeller			○				
Check condition of heat exchanger anticorrosion zinc		○	○				
Check thermostat function					●		
Flush cooling system							●
Adjust the tension of closed cooling system pump belt		○ 1 st time	○ (and thereafter)				
Intake / Exhaust system							
Check the air cleaner element			○				
Replace air cleaner element					○		
Check exhaust system		○ (and thereafter)					
Clean exhaust/water mixing elbow			○				
Electrical system							
Check and tighten electrical connections		○					
Clean battery cables					○		
Check the electrolyte level in the battery		○					
Engine and mounting							
Check for leakage of water and oil	○	○ (and thereafter)					
Tighten all major nuts and bolts Check tightness of mounting base vibromounts	○	○			●		
Check and adjusting intake / exhaust valve clearance							●
Check and adjust the injection fuel pump							●
Remote control system, etc.							
Check remote control operation		○	○ (and thereafter)				
Test run generator set		○					

○ In presence of this symbol it is possible to effect the technical support autonomously .

● In presence of this symbol it is obligatory to effect the technical support in an our retailer /workshop authorized by MASE.

6.22 ANOMALIES, CAUSES AND REMEDIES***The starter motor turns but the main engine does not start***

- Check that there is fuel in the tank. (Fill up)
- Check if the stop electromagnet is in the firing position. (Consult Service Centre)
- Check that the emergency button is in ON position. (Turn it on ON position)
- Check that the DC thermal breakers are on. (Restore)
- Bleed the air bubbles from the fuel circuit.

The engine protection module is not activated when the START button is pressed

- Check that the thermal protection switch is open. (Restore the contact pushing the button)
- Check battery cables and clamps, and electrical connections. (Reconnect)
- Check integrity of the battery. (Recharge or replace)

The generator switches off during the operating period

- Check if a protection has been activated with the relevant light coming on. (Remove the cause and retry starting)
- Check if there is fuel in the tank. (Fill up)

There is a high grade of smoke at the engine exhaust

- Check that the oil level in the sump does not exceed the MAX index. (Restore level)
- Check that the generator is not in overload.
- Check calibration of the injectors. (Consult Service Centre)

The engine runs irregularly

- Check the fuel filters. (Replace)
- Bleed the air bubbles from the fuel circuit.

The alternator voltage is too low

- Check the engine rpm: 1575-1590 rpm (52.5 - 53Hz) without utilities connected.
- Check that there is not a too heavy load. (Reduce the load)
- Regulator breakdown. (Contact Service Centre)
- Alternator failure. (Contact Service Centre)
- Check all electrical connections. (Contact Service Centre)

Starter battery flat

- Check the electrolyte level in the battery. (Restore the level)
- Check functioning of the DC alternator.
- Check integrity of the battery.

The generator does not deliver power

- Check that the magnetothermal switch is in the "ON" position. (Contact Service Centre)
- Regulator breakdown. (Contact Service Centre)
- Alternator failure. (Contact Service Centre)
- Check all electrical connections. (Contact Service Centre)

6.20 HOW TO ORDER THE SPARE PARTS

In order to ensure a good functioning of the generator, we recommend to use original spare parts only.

The spares can be purchased from the **mase** authorized assistance network (consult the **SERVICE** manual enclosed with the generator).

You can get **any further information** contacting the **mase** central Service.

7 TRANSPORT. STORAGE. LIFTING AND HANDLING AND PACKAGING

7.1 TRANSPORT AND STORAGE

Packaging: Supplied directly by Mase Generators. The total weight of the packed generator is given in Paragraph 2.3 “Table of technical characteristics”.

Transport: During transport the generator (with or without packaging) must be protected against atmospheric agents, it must not be turned upside down and must be protected against knocks.

⚠ CAUTION

It is strictly prohibited to pollute the environment with the packaging

Storage: The generator must be stored in horizontal position and away from atmospheric agents and humidity.

7.2 LIFTING AND HANDLING OF THE PACKED GENERATOR UNIT

⚠ CAUTION

Always check that the capacity of the lifting means and its accessories is greater than the weight of the generator printed on the identification plate.

Use a lift truck to handle the generator (with capacity greater than the weight of the generator indicated in the table of technical characteristics (par. 2.3) of the Use and Maintenance Manual), inserting the forks under the base at the lower part of the generator.

For handling on level ground, a transpallet is sufficient with a suitable capacity according to the table of technical characteristics (par.2.3) of the Use and Maintenance Manual.

ⓘ INFORMATION The centre of gravity of the generator corresponds to about the centre of its geometrical volume.

GB

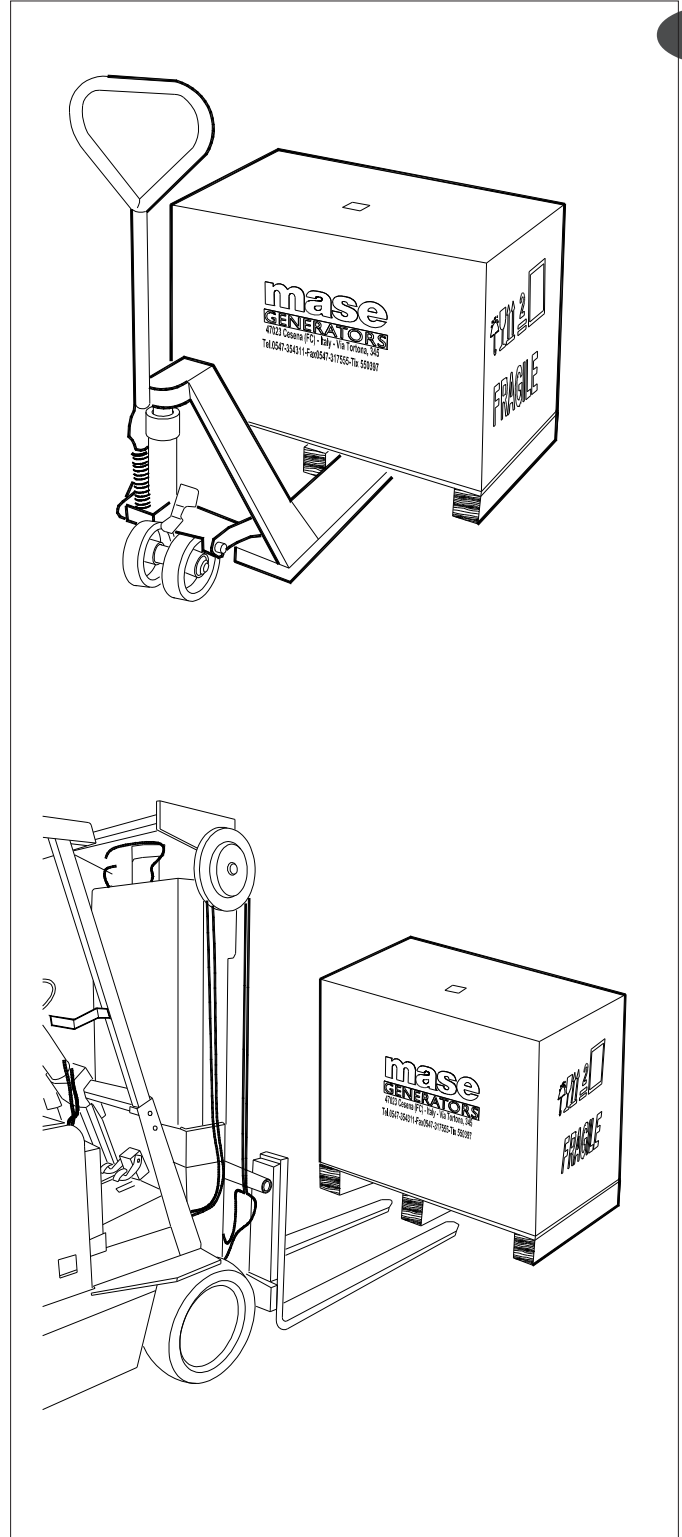

8 GUARANTEE AND RESPONSIBILITY

8.1 GUARANTEE

- The **mase** generators and all their components are guaranteed free of defects and are covered by the guarantee for a period as required by current legislation from the date of installation.
- Not covered by the guarantee are: failed observance of the installation regulations, damage caused by natural disasters, accidents, defects of the electrical system including the load to which the generator is connected, negligence, improper use or abuse by the operator and damage caused by repairs carried out by unqualified personnel.
- Repairs that cannot be carried out at the place of installation can be carried out at **mase** laboratories or at authorised workshops. Transport expenses will be borne by the Customer.
- Under no circumstances does the Customer have the right to claim compensation for damages or side effects caused by use of the machine in a manner not conform to what is described in this manual.

8.2 LIMITS OF RESPONSIBILITY

MASE GENERATORS S.p.A is responsible for anything regarding the safety, reliability and performance of the Generator on the condition that:

- The generator is used by persons trained through the use and maintenance manual.
- The installation is carried out according to **mase** instructions.
- The service procedures are carried out exclusively by **mase** specialised technical personnel.
- The electrical system and the loads to which the generator is connected is in conformity with the applicable CEI regulations.
- The Generator is installed and used in accordance with the installations provided in this manual.
- Use original spare parts specific to each model.
- Use suitable fuel.
- Diesel fuel conforming to standards ASTM A975.

9 DISPOSAL

9.1 DISPOSAL OF THE WASTE MATERIALS DERIVING FROM MAINTENANCE AND SCRAPPING

- The packaging used for transport is biodegradable and thus easy to dispose of by companies authorised for paper collection.
- The electrical components must be taken to companies authorised for the collection of electronic material.
- All the painted metal parts must be taken to companies authorised for the collection of metals.

WARNING

Please note that the system and its components contain materials that, if dispersed in the environment, may cause significant ecological damage.

The following materials must be delivered to specific collection centres authorised for their disposal:

- **Starting battery**
 - **Exhaust lubrication oils;**
 - **Mixtures of water and anti-freeze;**
 - **Filters;**
 - **Auxiliary cleaning material (e.g.: rags smeared or soaked with fuel and/or chemical cleaning products).**
- Any other material not listed above must be taken to companies authorised for the collection of industrial waste.

10 WIRING DIAGRAM

INSULATED POLE

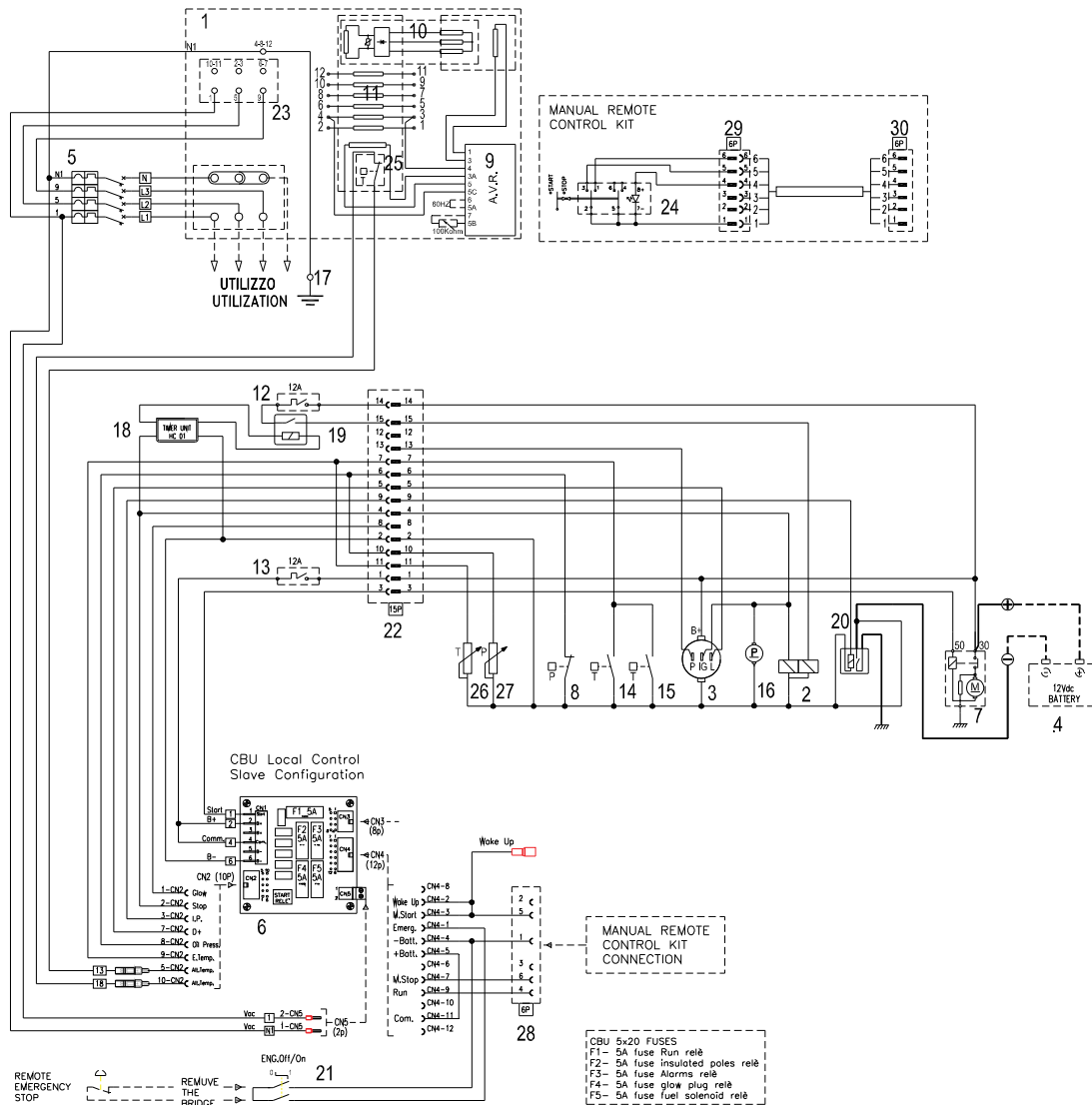

Cod.48597

- | | |
|--------------------------------|------------------------------|
| 1 ALTERNATOR | 19 RELAY |
| 2 STOP ELECTROMAGNET | 20 RELAY |
| 3 BATTERY CHARGER ALTERNATOR | 21 0/1 SWITCH |
| 4 BATTERY | 22 15 POLES CONNECTOR |
| 5 4-POLE MAGNETOTHERMAL SWITCH | 23 ALTERNATOR TERMINAL BOARD |
| 6 ENGINE PROTECTION MODULE | 24 START-STOP BUTTON |
| 7 STARTER MOTOR | 25 ALTERNATOR THERMOSTAT |
| 8 OIL PRESSURE SWITCH | 26 TEMPERATURE SENSOR |
| 9 ELECTRONIC VOLTAGE REGULATOR | 27 OIL PRESSURE SENSOR |
| 10 ROTOR | 28 6 POLES CONNECTOR |
| 11 STATOR | 29 6 POLES CONNECTOR |
| 12 THERMAL SWITCH | 30 6 POLES CONNECTOR |
| 13 THERMAL SWITCH | |
| 14 ENGINE THERMOSTAT | |
| 15 ENGINE THERMOSTAT | |
| 16 FUEL PUMP | |
| 17 GROUND CONNECTION | |
| 18 TIMER UNIT | |



Mase Generators S.p.a. • Via Tortona, 345 • 47522 **Cesena** (FC) ITALY • Tel. **(+39) 0547.35.43.11**
Fax **(+39) 0547.31.75.55** • www.masegenerators.com • e-mail mase@masegenerators.com